

FACTORY AUTOMATION

ROBOT SYSTEM SOLUTIONS

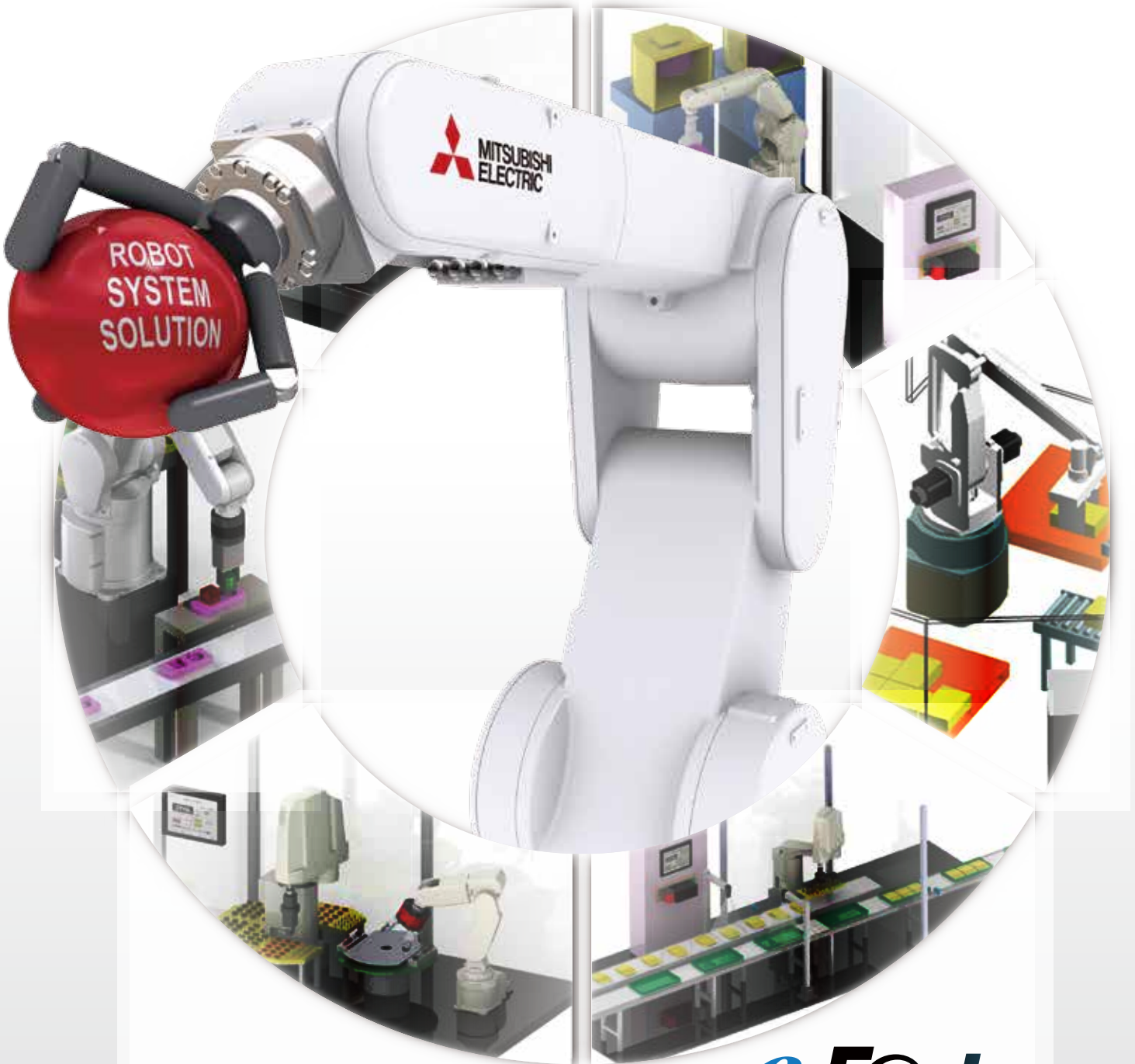

MELFA

e-Factory

 **iQ** Monozukuri

GLOBAL IMPACT OF MITSUBISHI ELECTRIC



Through Mitsubishi Electric's vision, "Changes for the Better" are possible for a brighter future.

Changes for the Better

We bring together the best minds to create the best technologies. At Mitsubishi Electric, we understand that technology is the driving force of change in our lives. By bringing greater comfort to daily life, maximizing the efficiency of businesses and keeping things running across society, we integrate technology and innovation to bring changes for the better.

Mitsubishi Electric is involved in many areas including the following

Energy and Electric Systems

A wide range of power and electrical products from generators to large-scale displays.

Electronic Devices

A wide portfolio of cutting-edge semiconductor devices for systems and products.

Home Appliance

Dependable consumer products like air conditioners and home entertainment systems.

Information and Communication Systems

Commercial and consumer-centric equipment, products and systems.

Industrial Automation Systems

Maximizing productivity and efficiency with cutting-edge automation technology.

Committed to ever higher customer satisfaction

e-F@ctory

FA integrated solution to reduce the TCO

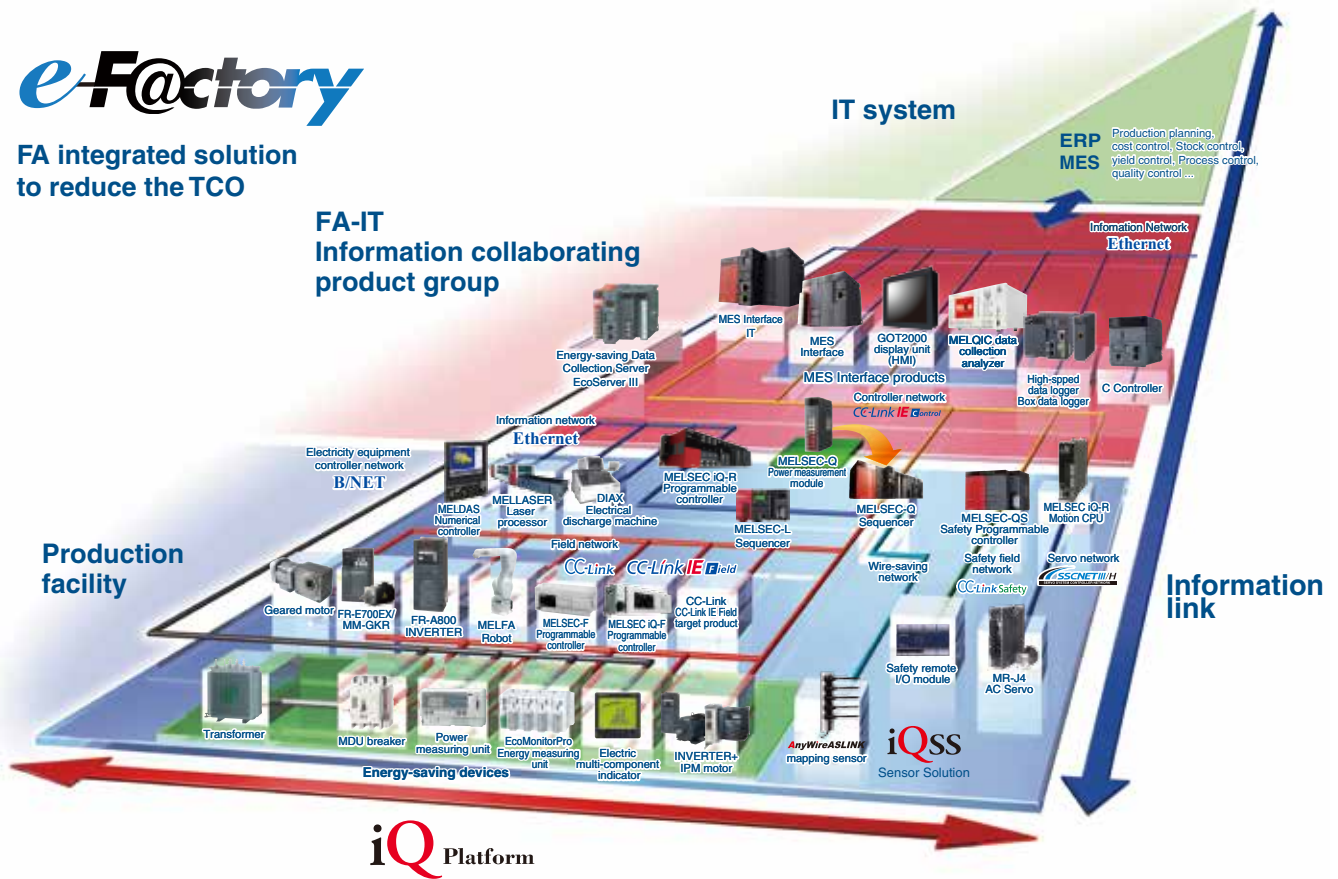

Mitsubishi Electric is a global leader in the research, manufacturing and marketing of electrical and electronic equipment used in areas such as communications, consumer electronics, industrial technology, energy and transportation. Within this, the industrial automation business has grown significantly since the first induction motor was manufactured over 90 years ago and has closely followed the automation industry in Japan, Asia, and

beyond. Mitsubishi Electric industrial automation boasts a wide-range of product areas such as production control, drives, and mechatronics that are used in various industries. In addition, Mitsubishi Electric offers e-F@ctory and iQ Platform, leveraging its total industrial automation solution portfolio. Mitsubishi Electric will keep offering products to customers all over the world as a total supplier of FA.

MITSUBISHI ROBOT SYSTEM SOLUTION

Mitsubishi Electric Corporation is a leading maker of factory automation systems, and has abundant experience in various areas including automobile parts, electronic and electric components, liquid crystal displays, semiconductors, food products, medicines, cosmetic products, potteries, education and research.

The company proudly offers the best of its kind intelligent solution with highly rigid arms which enable high-speed and high-precision operations, to support factories, to arrange optimization and to be one step ahead of other manufactures.



to upgrade their production lines thereby improving

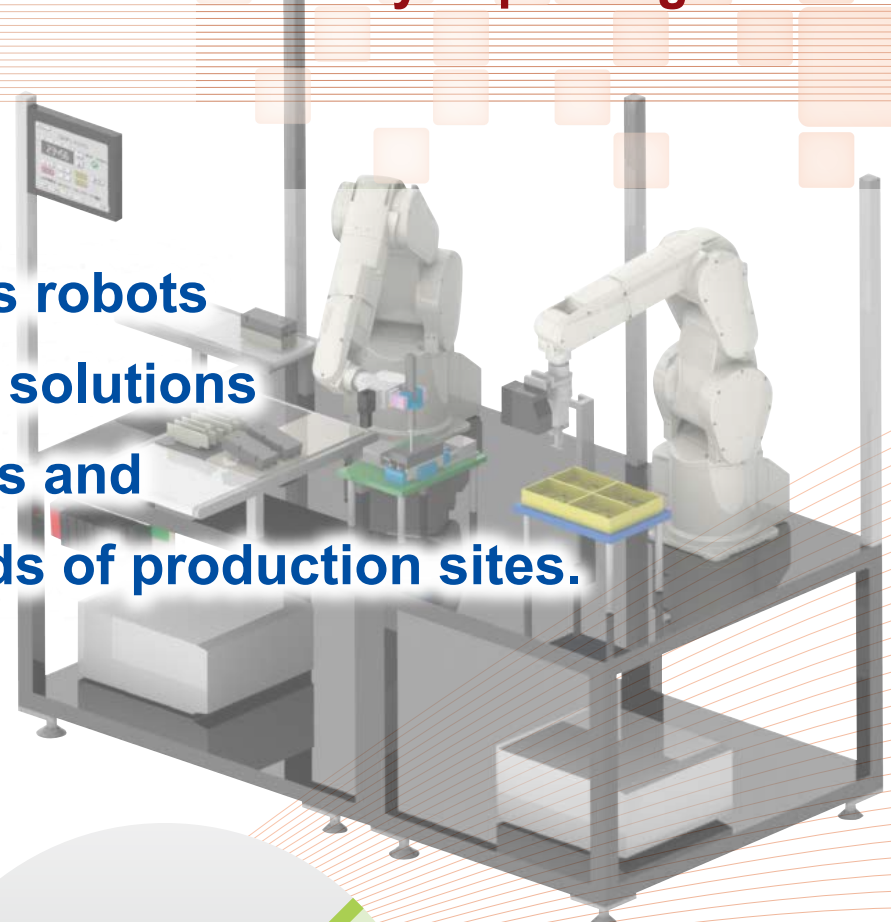

Mitsubishi Electric's robots and robotic system solutions solve various issues and satisfy diverse needs of production sites.

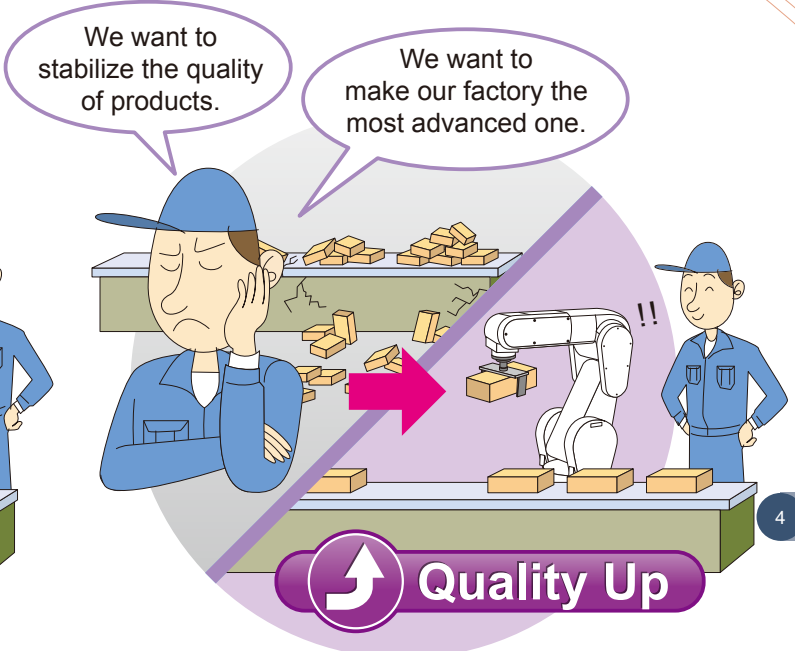
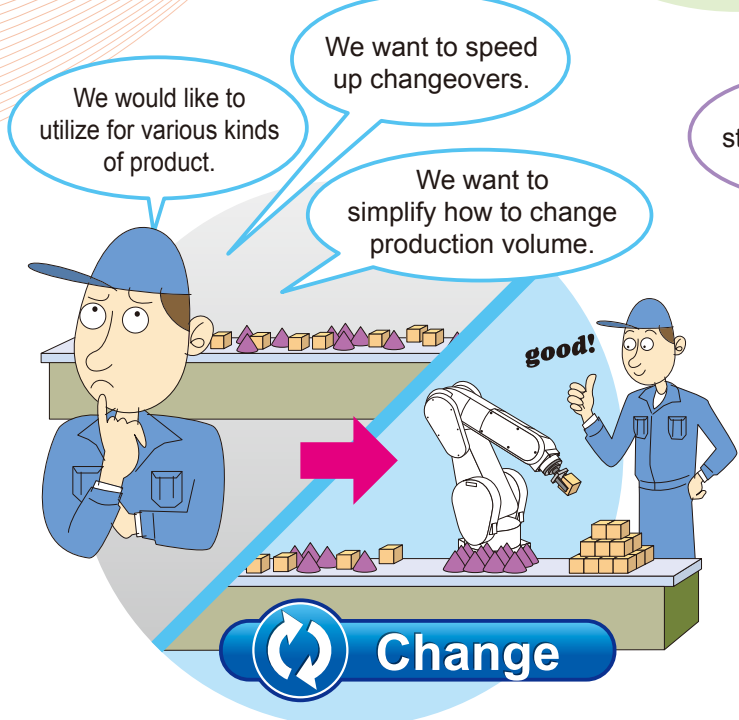
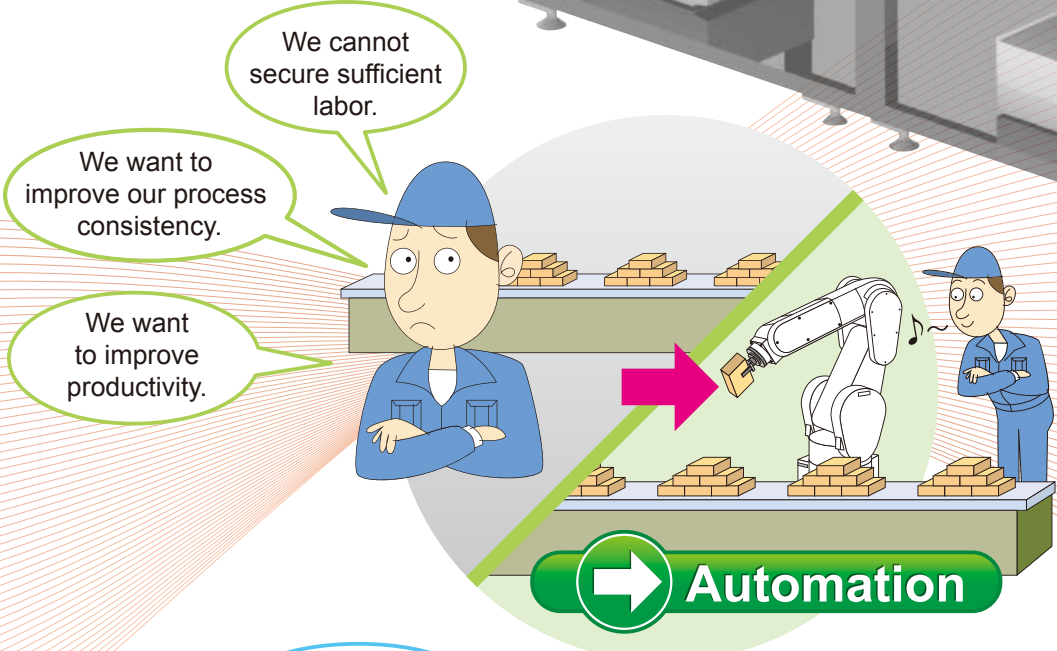

Smooth system configuration!!

- We propose the most appropriate automation system out of our ample FA products.
- There are various ways to learn how to operate a robot in advance, such as e-learning and Robot School. Note 1)
- Call center is available for consultation for operating method and programming, including sudden needs such as a startup at a production site.
- In partnership with experienced system integrators (SI), we will provide proposals which satisfy your requests.



One of customers' concern is how to build a system.

To automate a plant, you will face various issues
Mitsubishi Electric will provide customers with reliable

Plant automation with the most appropriate costs!!

- By utilizing a wide range of functions, interface and components of robots, we will realize automation with the minimum peripherals.
- Customers can select the best robots for their layouts from an abundant lineup of robots.
- We will support our customers to implement the most appropriate system introduction in partnership with experienced system integrator partners.

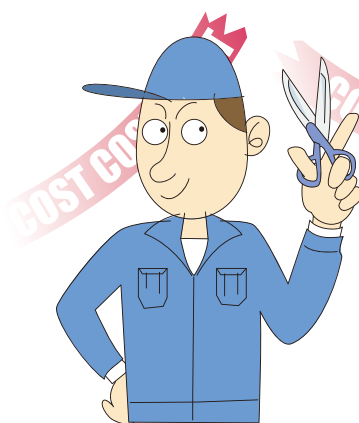

Customers are concerned about costs.



questions regarding the introduction of robots.

The best safety measures!!

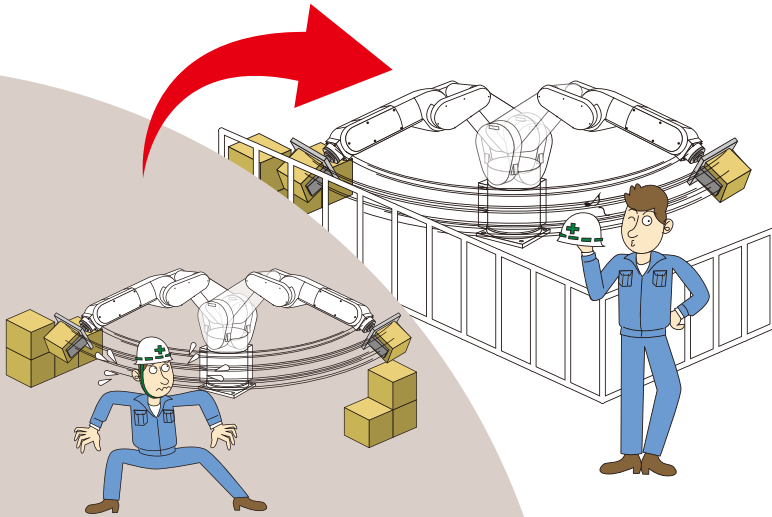

Customers are worried about safety measures.

- At Robot School, customers can learn about matters to be observed regarding the usage of robots such as the installation of a safety fence and a door switch. Note 2)
- Robots are equipped with various safety functions to ensure the safety of operators.
(They are in compliance with ISO-10218, Safety Requirements for Industrial Robots.)
- We will propose our customers safe and comprehensive solution with our wide range of safety product lineup.

and concern.

support for the introduction of robots in their plants.



Customers want to know if they will be well looked after at the time of malfunction.

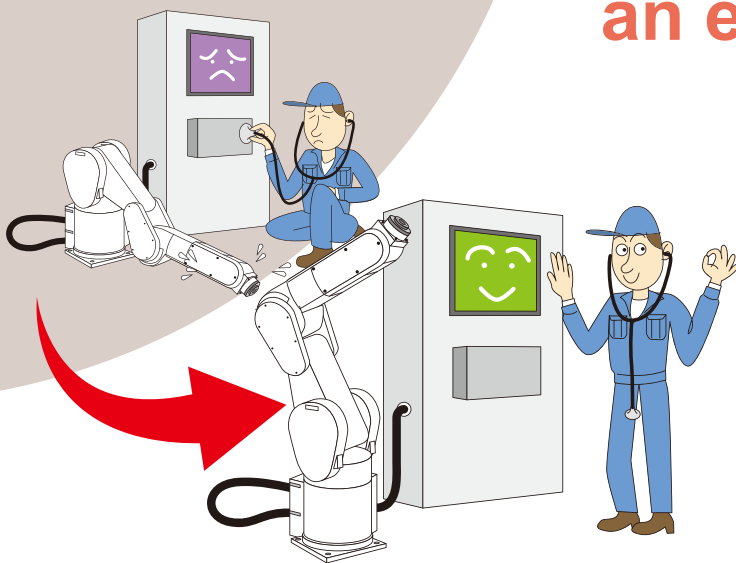

Shorter downtime at an emergency case!!

- We globally deploy our after-sales service offices for factory automation equipment and robot which are the key parts of automation systems to establish a reliable support system.
- Utilizing our expertise in factory automation equipment, we will support customers to be equipped with necessary maintenance functions.
- We will provide our support to customers for the design, delivery and maintenance of a robot system through the strong alliance with our partners.

Assembly of electric equipment



Case study: Page 9,10



- Manpower saving
- Adaptation to a wide variety of products
- Stabilization of quality

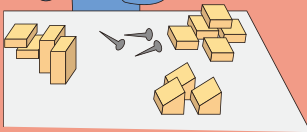

Loading/Unloading of parts to a processing machine



Case study: Page 11,12

- Manpower saving
- Higher operating ratio
- Improvement in cycle time

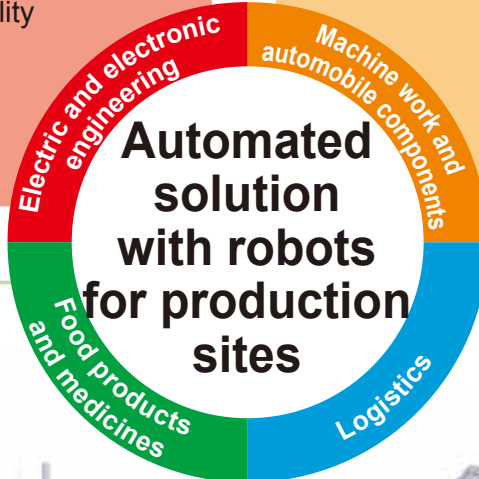
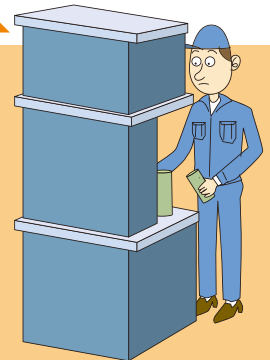

Alignment and packaging



Case study: Page 13,14

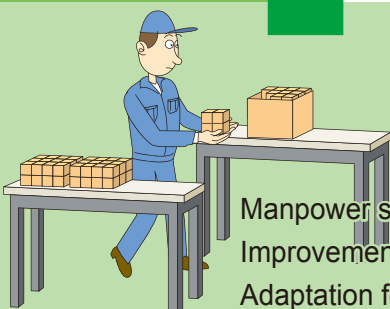

- Manpower saving
- Improvement of traceability
- Adaptation for load changes

Handling of packed carton boxes

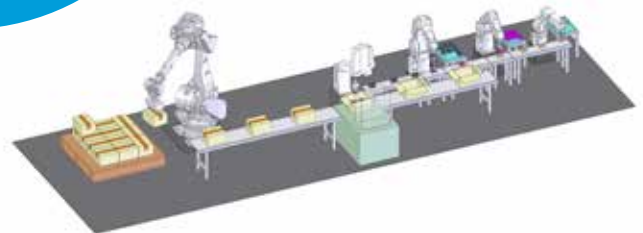

Case study: Page 15



- Manpower saving
- Improvement in cycle time
- Reduction of heavy labor

Merits of robot introduction

Productivity improvement

Productivity will be improved.

Fast!

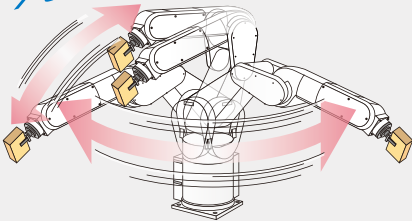

It enables high-speed operation. Continuous operation is possible even at workers' recess time and midnight.

Manpower will be saved.

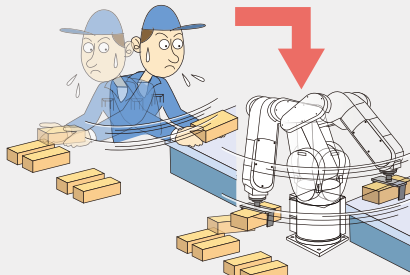

Robots work taking over the hands and arms of operators. (Robots are able to duplicate complicated movement.)

Product quality will be improved.

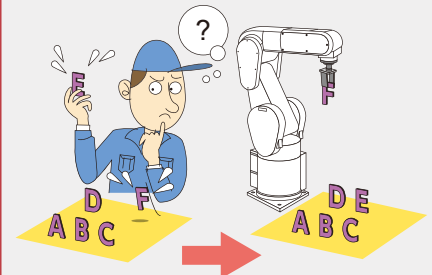

Since the movement of robots is consistent, there is no mistake such as skipping attachment of a component.

Reduction of total costs

Versatile system can be created. (Adaptation to a wide variety of products.)

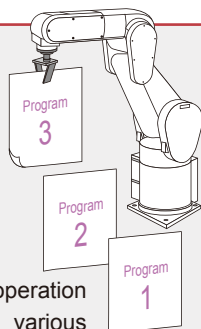

Robots enable a quick operation mode change by saving various complicated moves and allowing program and automatic hand change.



Device tends to have complicated structure which requires changeovers of various parts.

It is easy to change to a new model and to switch to another operation.

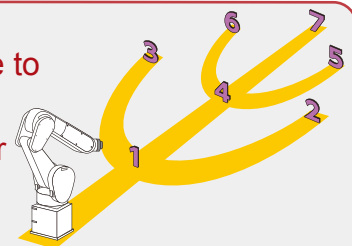

Moves of robots are flexibly changeable, so it is easy to add a product type and a process in the future. When a line is stopped, a robot can be easily utilized with another production facility.



It is necessary to newly design and manufacture a machine for the change and it requires costs.

The start-up time of system will be shortened. There will be fewer troubles at a start-up and adjustment time will become shorter.

Teaching



Programming



Automatic operation

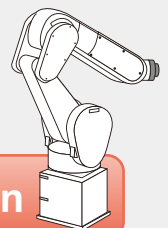

Since the system is flexible, it is easy to design coordinating with other peripherals. In addition, at the installation, there is no need to adjust a position against those of peripherals, which reduce a start-up time.



Since it requires dedicated work, it requires a long time to design and manufacture a machine. In addition, it is not flexible, so it takes a very long time to adjust a position at the installation.



Electric and Electronic Engineering

Assembly of electric components (switch)

System configuration diagram

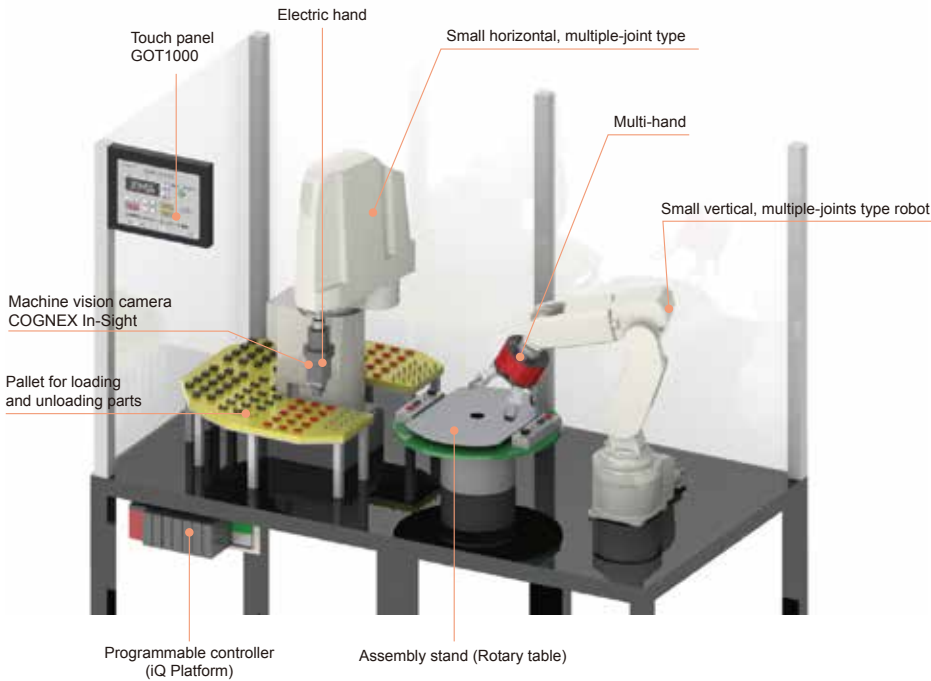

Points for the employment of robots

High-speed parts kitting with a horizontal, multiple-joint type robot, fine assembly with a vertical, multiple-joint type robot, and the ability to handle a variety of workpieces with a high-functioning hand (a multi-hand and an electric hand)

High-speed kitting

It enables high-speed picking from multiple pallets.

Capable of handling a wide variety of workpieces using only a small space

Utilizing a small horizontal, multiple-joint type robot which has a wide motion range requiring a small installation space, a plant can keep a various kinds of parts as a stock using a smaller space.

No need to change hands to switch a kind of work

Easily attachable electric hand can flexibly handle parts with different sizes and configurations.

Complicated assembly process

A small vertical, multiple-joint type robot, which is versatile and has a wide motion range, processes a complicated assembly process at a low cost.

Reduction of cycle time

Easily attachable four-head multiple hands can process continuous mounting of parts.

Control device configuration diagram

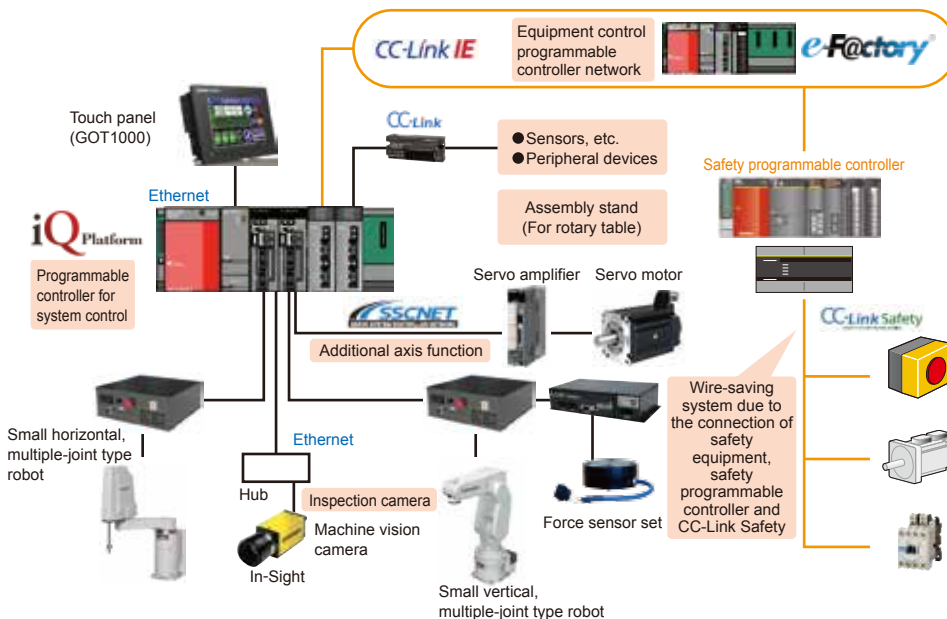

iQ Platform strengthens the link between programmable controller, GOT and a robot. It enables the best system operation and visualization. In addition, it realizes effective production control utilizing various networks and MES interface.

Reduction of cycle time with iQ Platform, which arranges high-speed communication between a robot and a programmable controller.

Unit-saving with the robot's Additional axis function

Easy connectivity with COGNEX machine vision camera

Visualization of data by linking factory automation equipment and wire-saving of various networks

Benefits of introducing

- Manpower-saving with the introduction of facility: It is possible to depreciate the investment cost in about 2 years. (Note: The calculation is based on the conditions that Mitsubishi Electric uses.)
- Introduction merit due to increased production capacity: Production will increase about 2.5 times due to the shorter cycle time and longer operating hours. (Note: The calculation is based on the conditions that Mitsubishi Electric uses.)

Other merits: Adaptation to the production of a wide variety of products, the simplification of production adjustment, and the stabilization of quality

factory automation system makers, will provide systems through the strong alliance with partners.

Appearance inspection

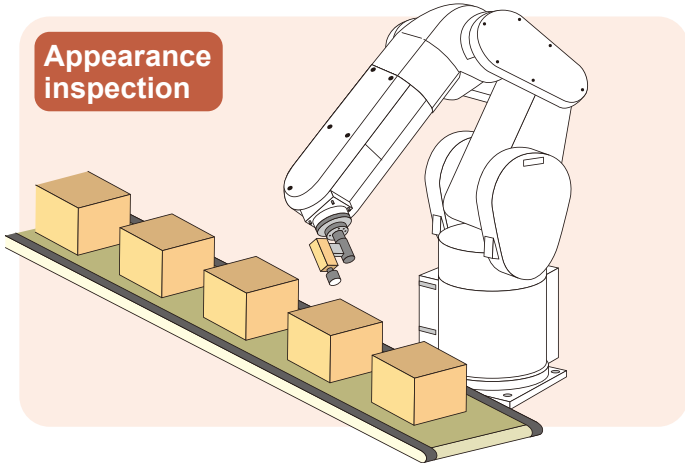

Laser marking

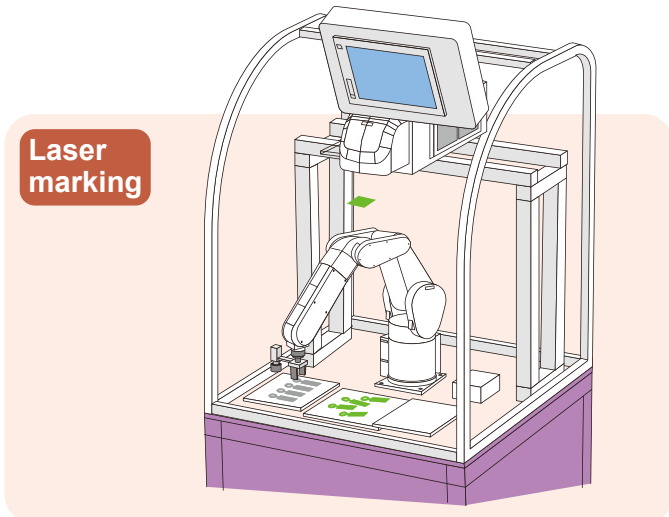

Soldering

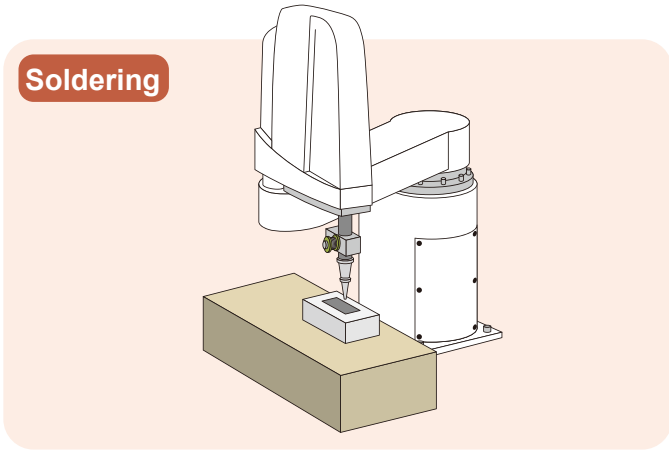

Screw fastening

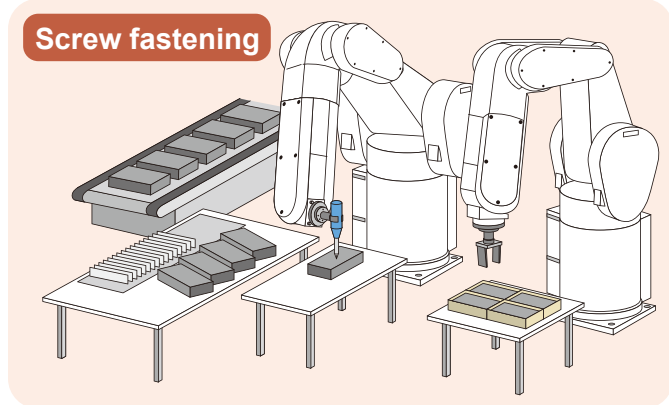

Sealing

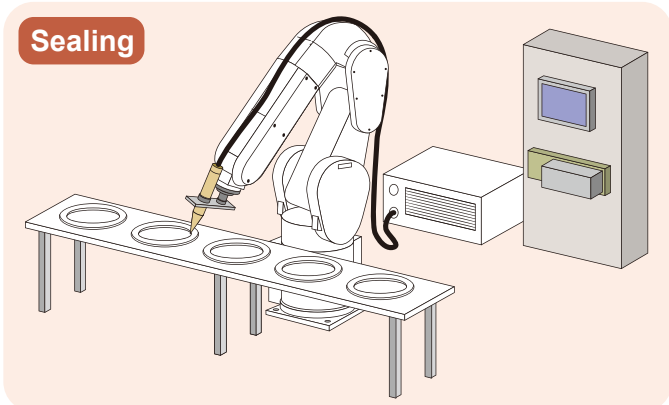

Mounting of parts



Kitting

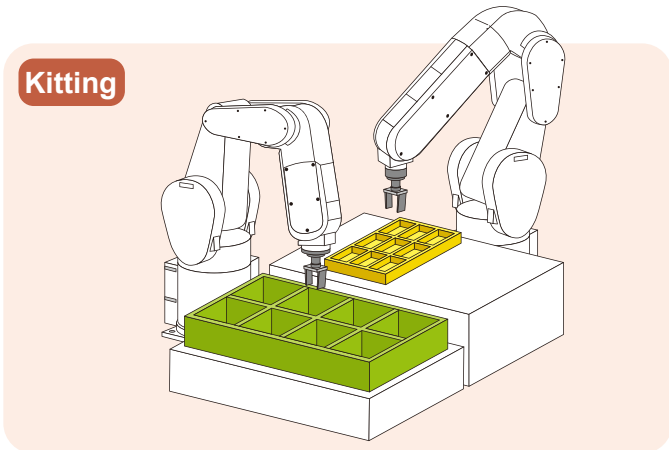



Machine work and automobile components

Loading/Unloading of parts to a processing machine (A lathe, a machining center, a press machine, and a make-up machine, etc.)

System configuration diagram

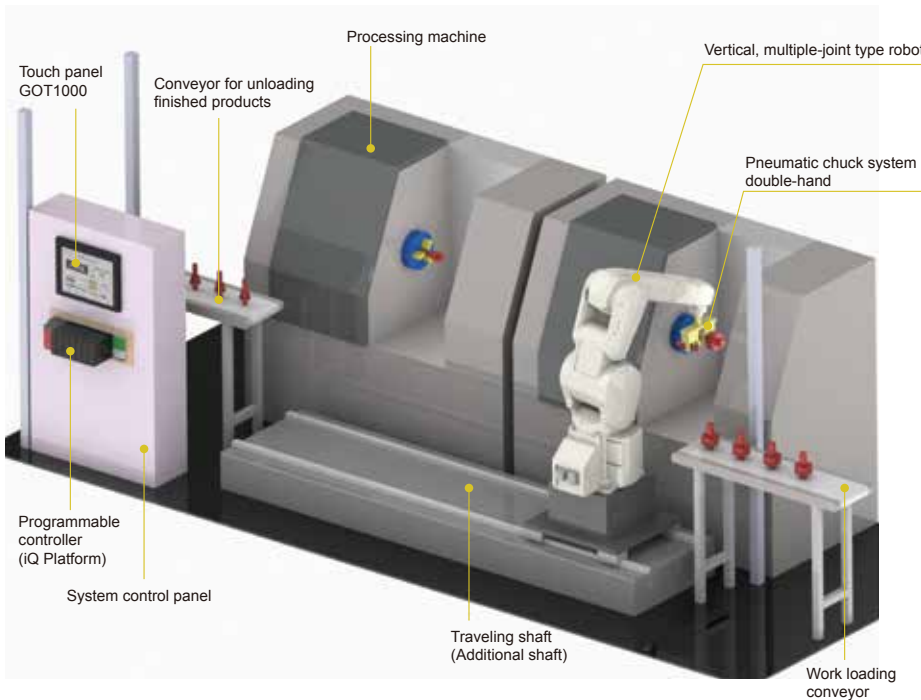

Points for the employment of robots
 A vertical, multiple-joint type robot realizes high-speed loading and unloading of parts to a processing machine. (Oil mist proof) Additional traveling shaft improves the operating rate of a robot and efficiently utilizes the facility.

Improvement of environmental resistance

Oil mist proof assures a safe access to a processing machine.

Smooth hand-over of products with various processing machines

It is possible to place a robot in many styles changing the height and the positions of arms, enabling smooth hand-over of products with processing machines.

Higher operating rate of robot

One robot can be slid to access multiple number of processing machines during its operation.

Shorter cycle time

Double-hand operation minimizes the time to replace a workpiece in a processing machine.

Control device configuration diagram

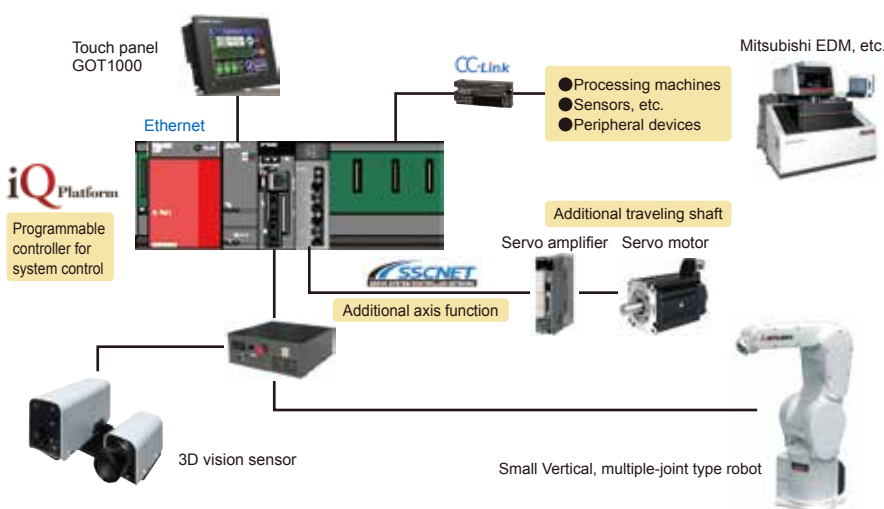

iQ Platform strengthens the link between programmable controller, GOT and a robot. It enables the best system operation and visualization.

In addition, it realizes effective production control utilizing various networks and MES interface.

Reduction of cycle time with iQ Platform, which arranges high-speed communication between a robot and a programmable controller.

Unit-saving with robot's Additional axis function

Visualization of data by linking factory automation equipment and wire-saving of various networks

Benefits of introducing

- Manpower-saving with the introduction of facility: It is possible to depreciate the investment cost in about 1 year. (Note: The calculation is based on the conditions that Mitsubishi Electric uses.)
- Introduction merit due to increased production capacity: Production will increase about 1.5 times due to the longer operating hours. (Note: The calculation is based on the conditions that Mitsubishi Electric uses.)

Other merits: Adaptation to the production of a wide variety of products, the simplification of production adjustment, and the reduction of dangerous work

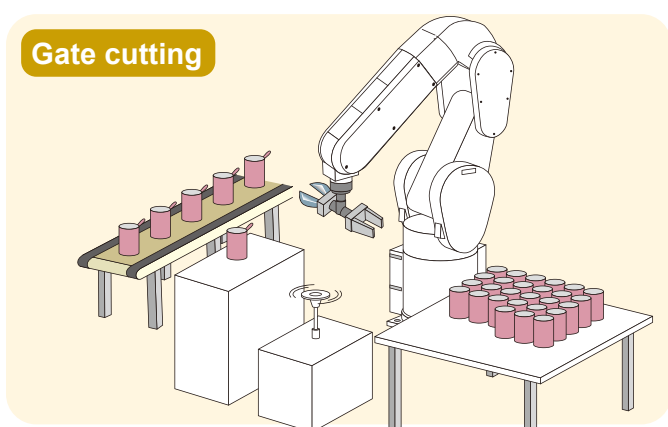
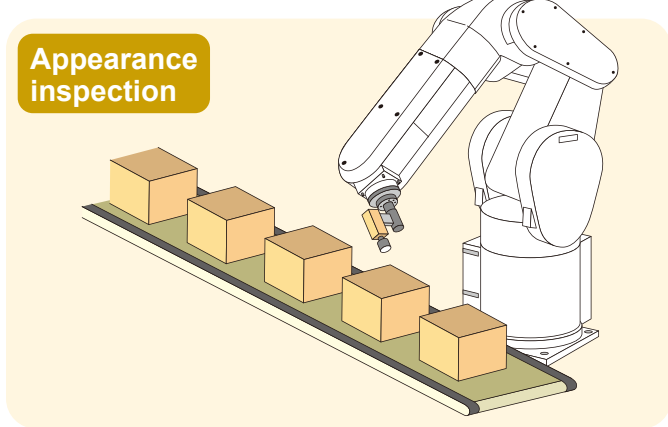
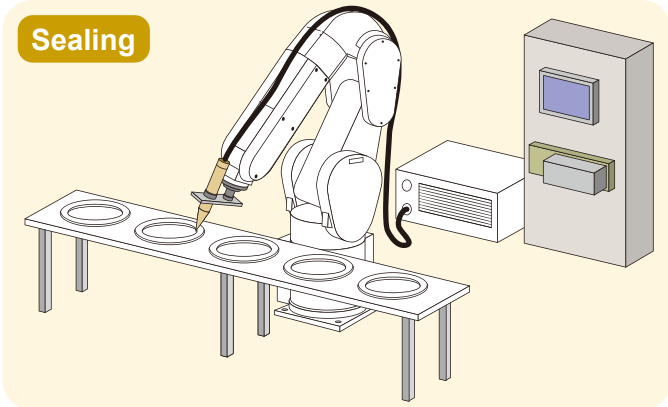
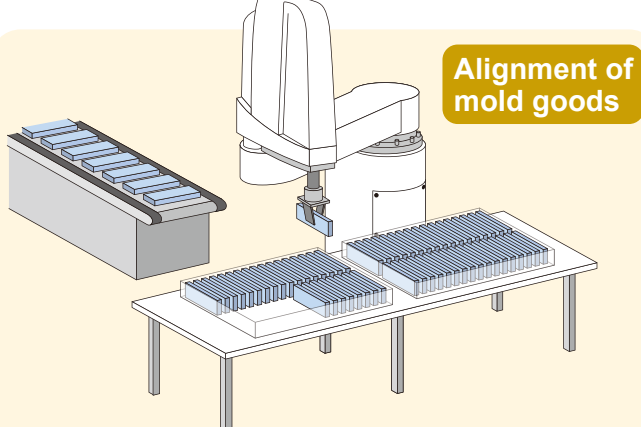
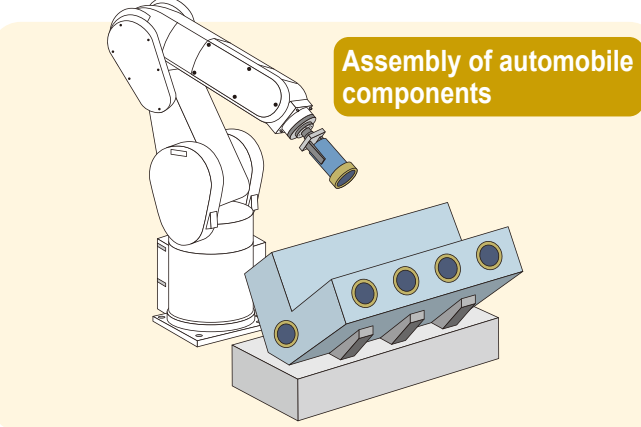
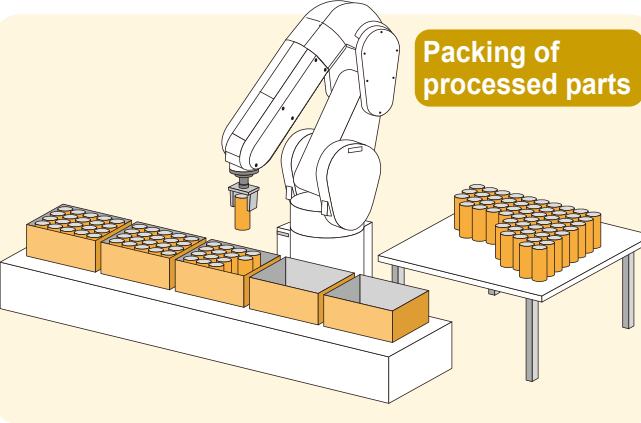
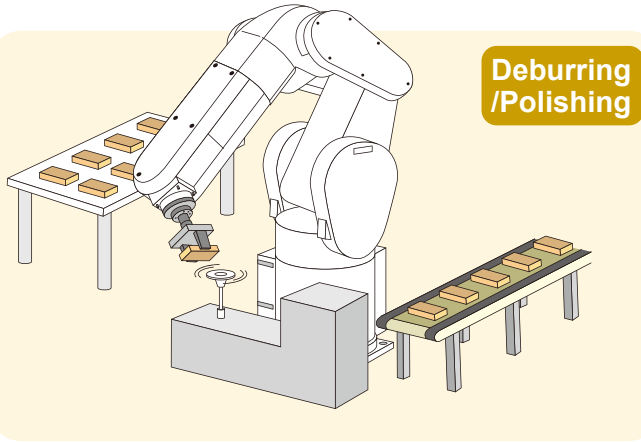



Food Products and Medicines

Conveyor alignment for packed food products

System configuration diagram

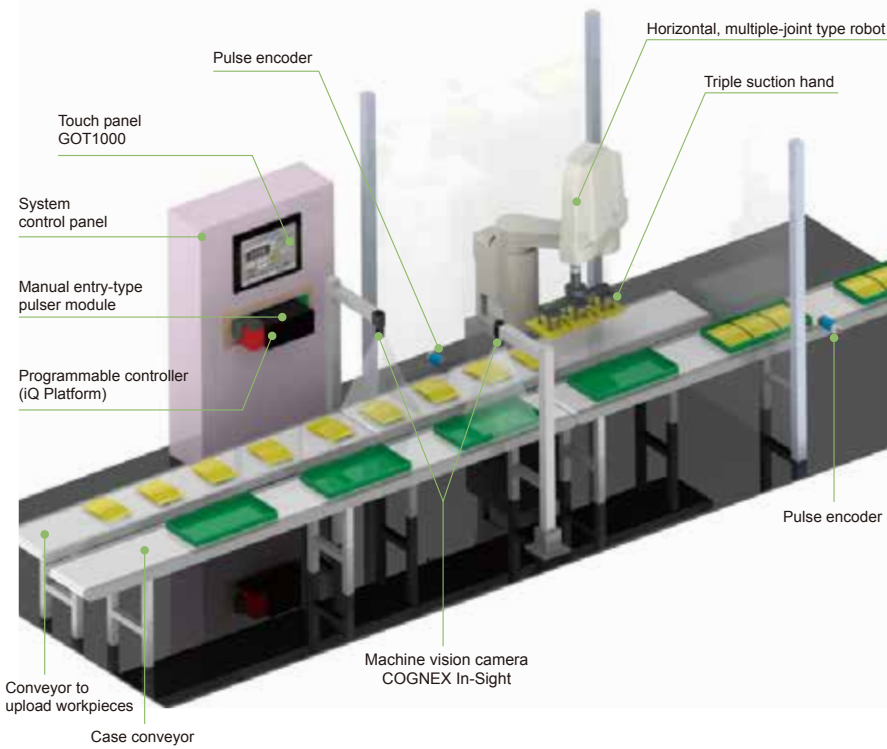

Points for the employment of robots

High-speed vision-tracking of horizontal, multiple-joint type robot realizes non-stopping alignment process. It also processes simultaneous tracking for multiple conveyors.

High-speed tracking

Tracking function of robot allows the line to arrange transfer and alignment processes while easily following the moves of workpieces on a conveyor.

No need of alignment device

No dedicated alignment device is required due to the utilization of machine vision camera, which contributes to the setup of versatile system at a low cost.

Reduction of cycle time

Synthesis rate of joint of horizontal, multiple-joint type robot realizes the highest speed and highly accurate operation of its kind.

Stable quality due to automated process

Highly accurate repeating movement of robot eliminates the variation in quality due to the quality and operating speed of each operator.

Control device configuration diagram

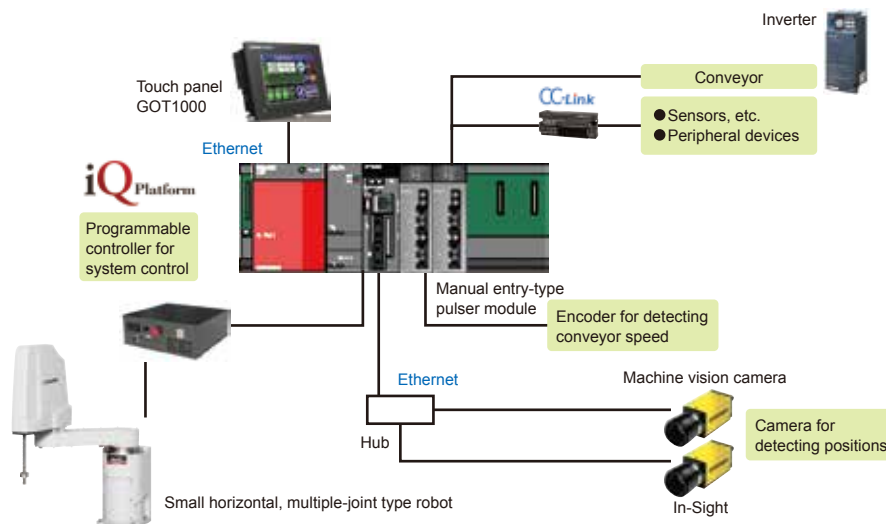

iQ Platform strengthens the link between GOT and a robot. It enables the best system operation and visualization. In addition, it realizes effective production control utilizing various networks and MES interface.

Reduction of cycle time with iQ Platform, which arranges high-speed communication between a robot and a programmable controller

Easy connectivity with COGNEX machine vision camera

Visualization of data by linking factory automation equipment and wire-saving of various networks

Benefits of introducing

- Manpower-saving from the introduction of facilities: It is possible to depreciate the investment cost in about 1.5 years. (Note: The calculation is based on the conditions that Mitsubishi Electric uses.)
- Introduction merit due to increased production capacity: Production will increase about 1.5 times due to the longer operating hours. (Note: The calculation is based on the conditions that Mitsubishi Electric uses.)

Other merits: Adaptation to the production of a wide variety of products, the simplification of production adjustment, and the stabilization of quality

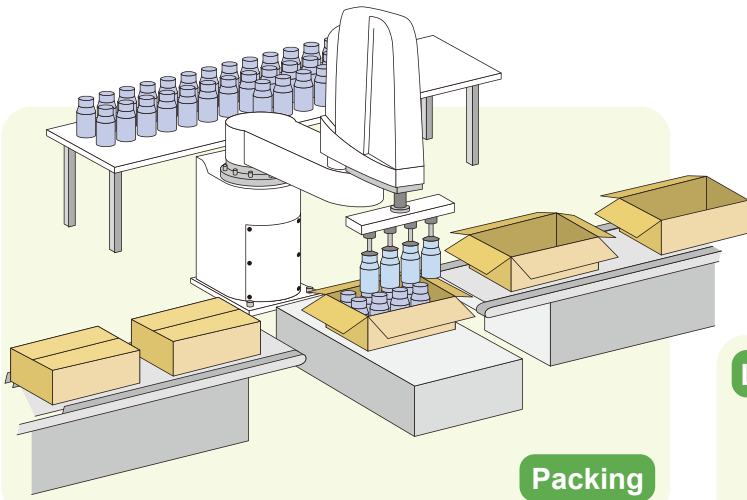

Packing

Label check

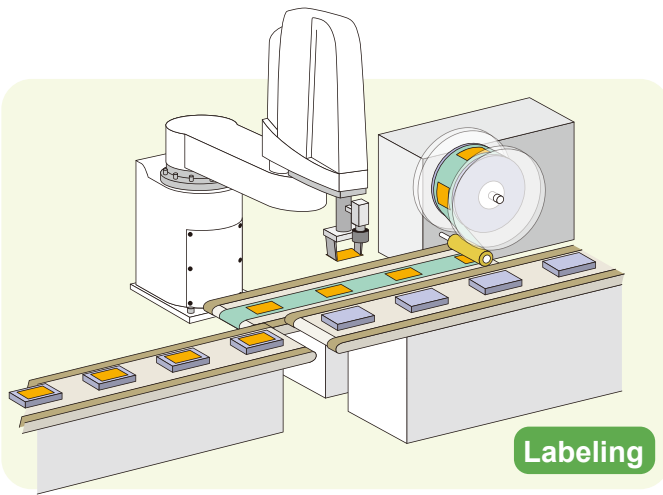
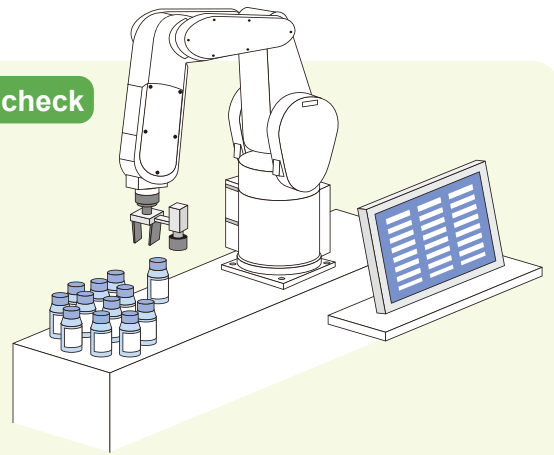

Labeling

Sorting

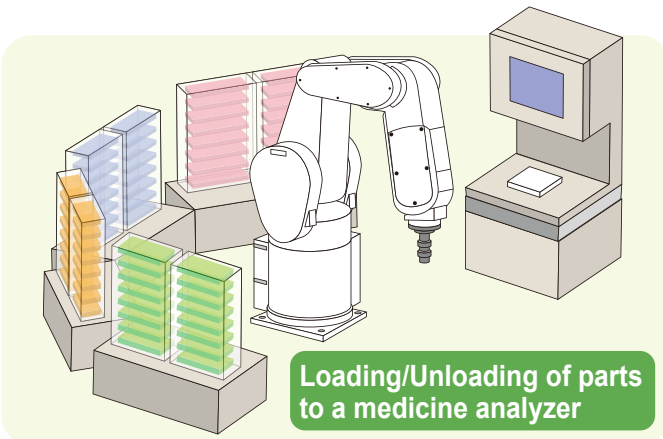
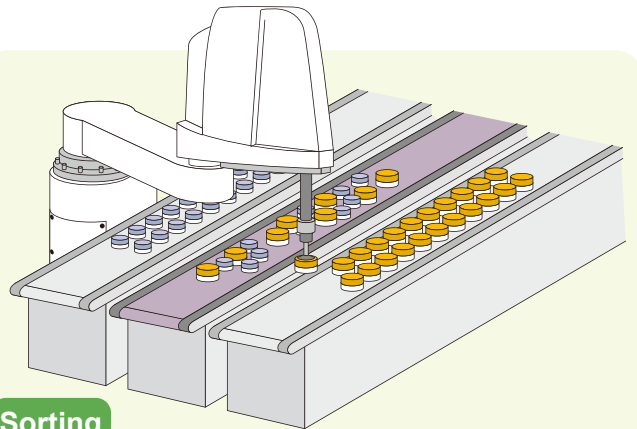

Loading/Unloading of parts to a medicine analyzer

Loading/Unloading processes for a filler

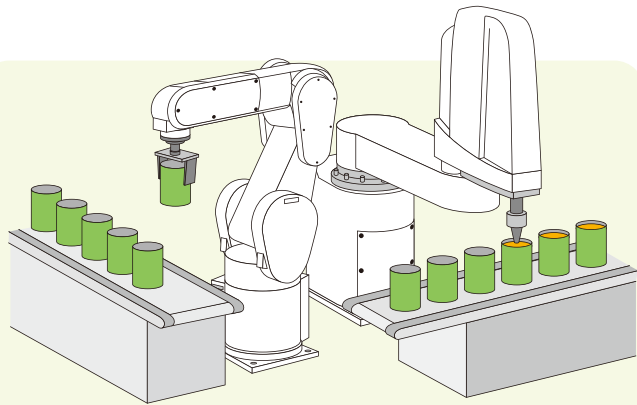



Palletize

Palletize of carton boxes

System configuration diagram

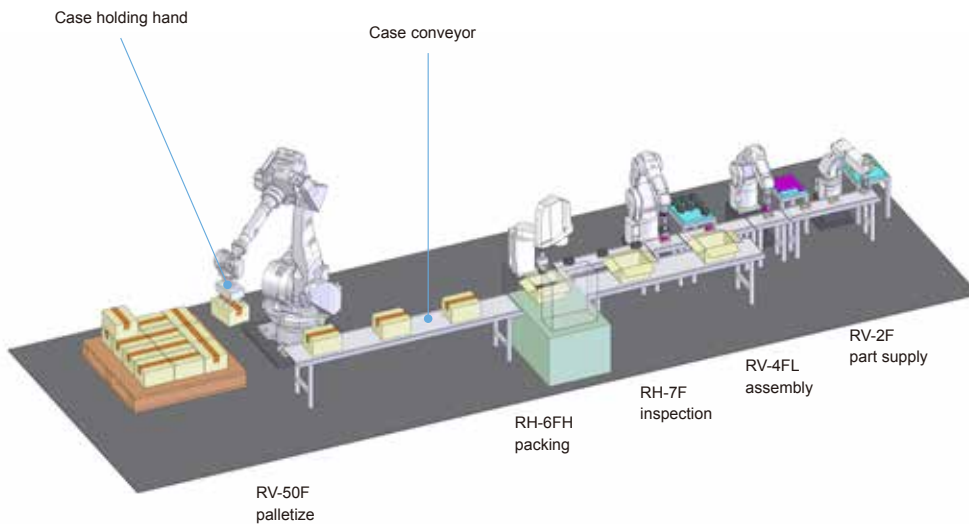

Points for the employment of robots

A robot enables high speed palletizing operation. The length and structure of arms, which have been optimized for palletizing process, improves the flexibility of layout.

High-speed operation

The use of robot assures the highest speed palletizing of its kind.

Reduction of cycle time

To make the most use of the ability of robot, the most appropriate speed control is adopted depending on the load and the condition of posture of the robot.

Flexible layout

The optimized arm length and structure minimizes an idle space around a robot for the operation using standard pallet sizes.

Stable quality due to automated processes

Highly accurate repeating movement of robot eliminates the variation in quality due to the quality and operating speed of each operator.

Control device configuration diagram

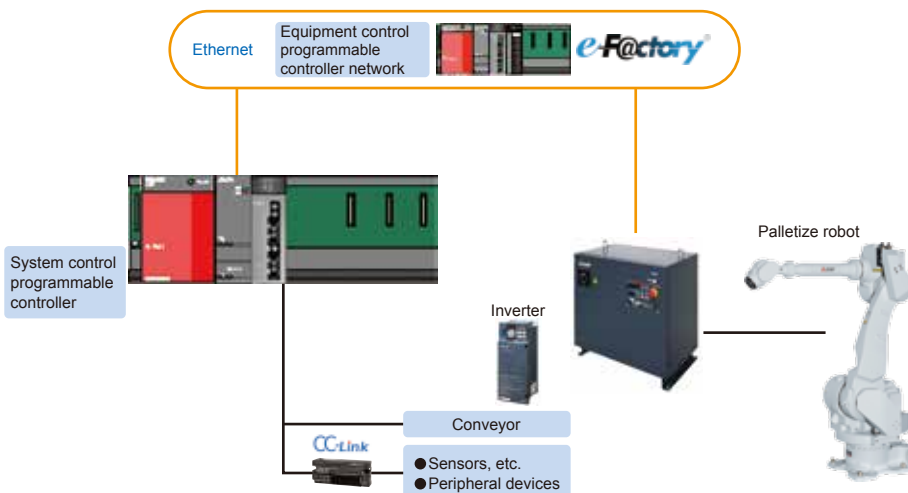

Substantial network function including CC-Link and Ethernet assures the connectivity with upper programmable controllers and computers.

Visualization of data by linking factory automation equipment and wire-saving of various networks

Benefits of introducing

- **Manpower-saving from the introduction of facilities:** It is possible to depreciate the investment cost in about 1.5 years. (Note: The calculation is based on the conditions that Mitsubishi Electric uses.)
 - **Introduction merit due to increased production capacity:** Production will increase about 4 times due to the shorter cycle time. (Note: The calculation is based on the conditions that Mitsubishi Electric uses.)
- Other merits: The simplification of production adjustment, the stabilization of quality, and the reduction of heavy labor



Clean room

Loading and unloading from cassettes

System configuration diagram

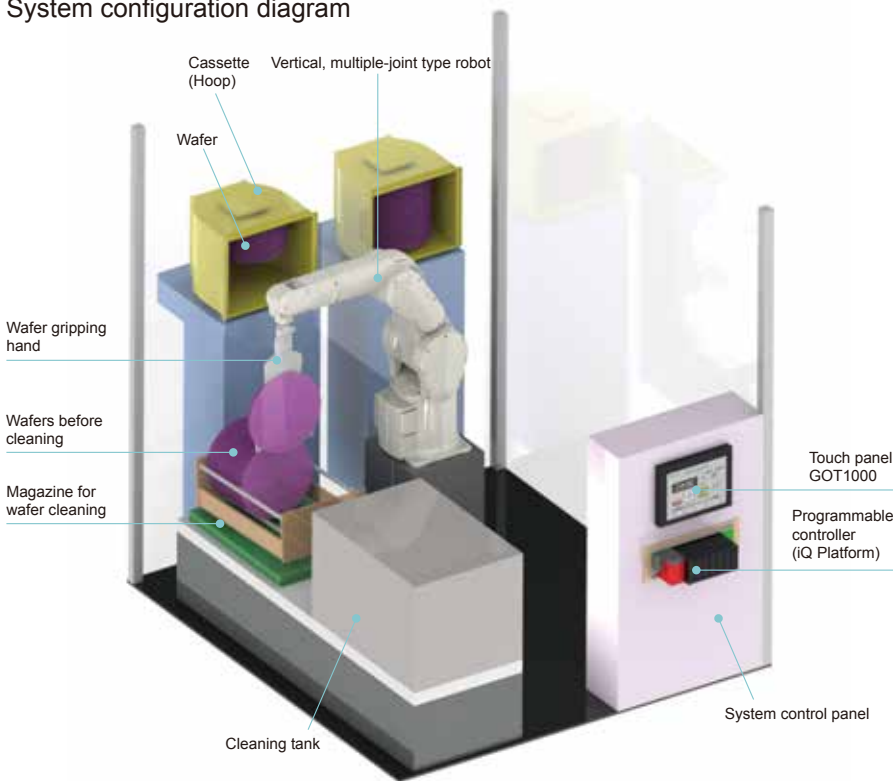

Points for the employment of robots

It is possible to perform high-speed loading and unloading of wafer cassettes (hoops) by a vertical, multiple-joint type robot (Long arm and clean room compatible).

Clean room compatible

Clean-type robot is used to satisfy ISO Class 3 clean room.

Space-saving

Layout is space-saving type which utilizes a wide motion range of robot.

Supporting various cassette types

It is possible to hand over wafers to cassette in various styles and requires no dedicated machine such as an inverting machine.

Control device configuration diagram

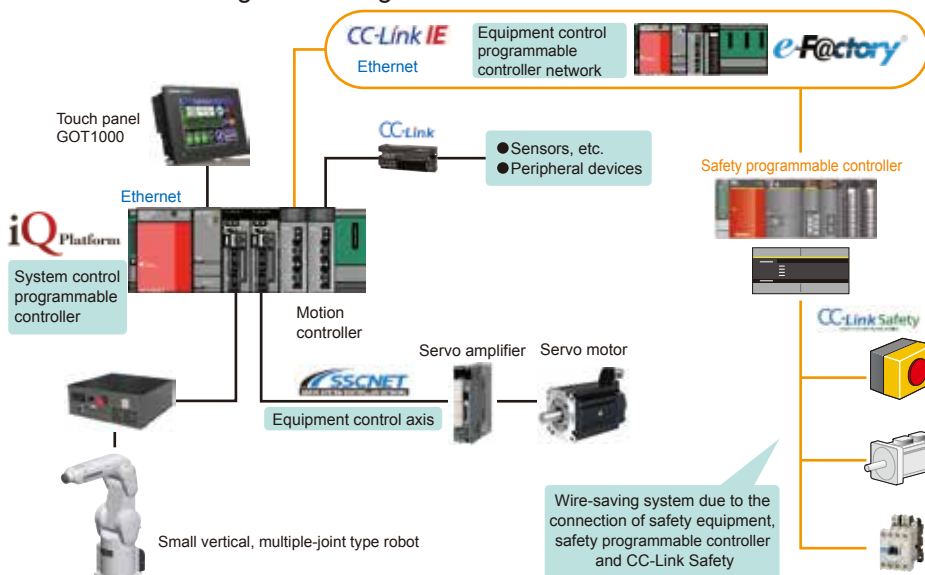

iQ Platform strengthens the link between programmable controller, GOT and a robot. It enables the best system operation and visualization. In addition, it realizes effective production control utilizing various networks and MES interface.

Reduction of cycle time with iQ Platform, which arranges high-speed communication between a robot and a programmable controller.

Visualization of data by linking factory automation equipment and wire-saving of various networks

Benefits of introducing

The improvement of cleanness, manpower saving, higher productivity, and the simplification of production adjustment

No more worries about introduction of robots to your facilities. Application to draw excellent functions and performance of robots can be easily configured.



e-Factory

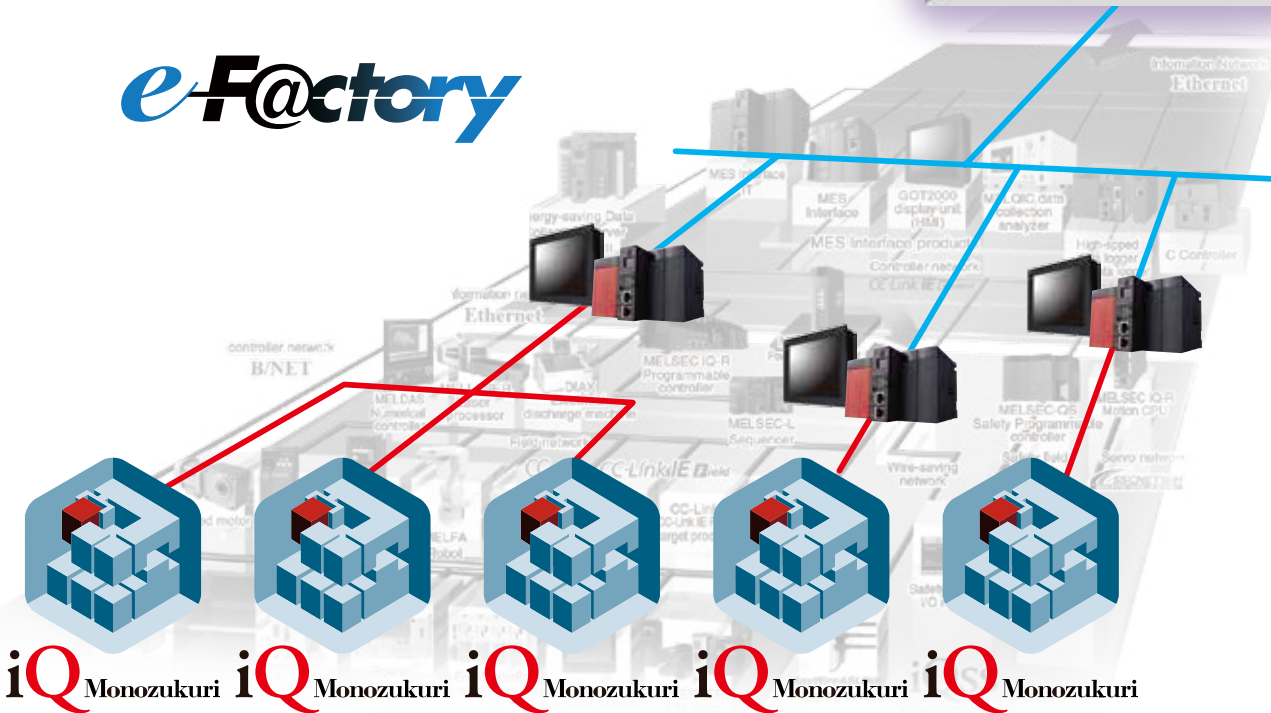

iQ Monozukuri **iQ Monozukuri** **iQ Monozukuri** **iQ Monozukuri** **iQ Monozukuri**

System design

Since essential components are included in a package, burden for system consideration can be reduced.

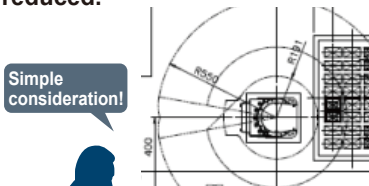

Device connection/setting

Anyone can connect various devices using ready-to-operate robots, easy wiring, and piping.

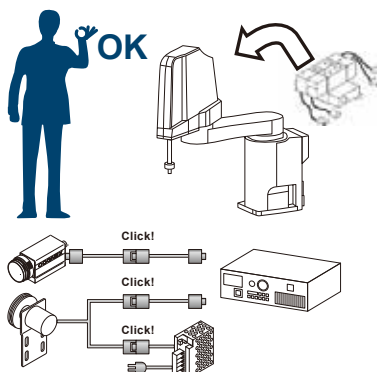

Programming/setup

Systems can be easily configured using dedicated application programs and startup tools.

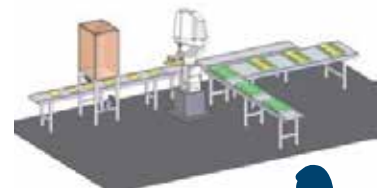

configuration of automation systems are packaged.

Package configuration image

Devices, application programs, and useful startup tools required for automation system configuration and startup are all included in this package.

Robots and controllers

Wiring, piping, and parameter settings have already been performed to the robots.

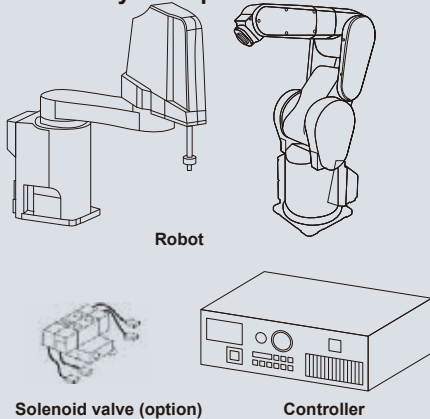

1) Application program

Pre-installed robot programs

Ovrd
Mov
MvSpl

2) Setup wizard and setting tools

PC tools for easy startup



3) Peripheral device set

Hands, sensors, and other devices are included.

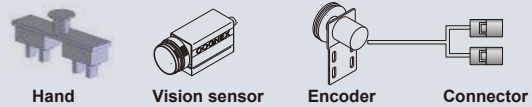

Based on actual performance of various system configurations, Mitsubishi will extend the variety of packages appropriate for various applications, mainly for Mitsubishi industrial robots.



Deburring/Polishing



Tracking

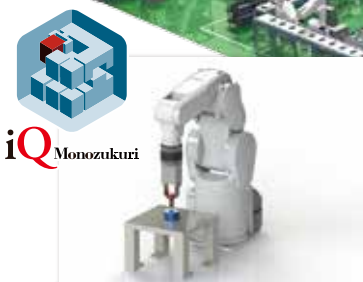

Force-sense

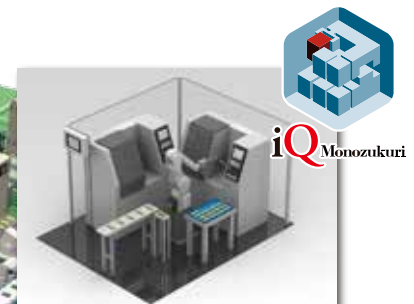

Loading

<Applicable applications are and will be added.>

► Conveyor Tracking Application

Vision cameras detect workpieces on conveyors. Workpieces are transported and aligned by robots without stopping conveyors.

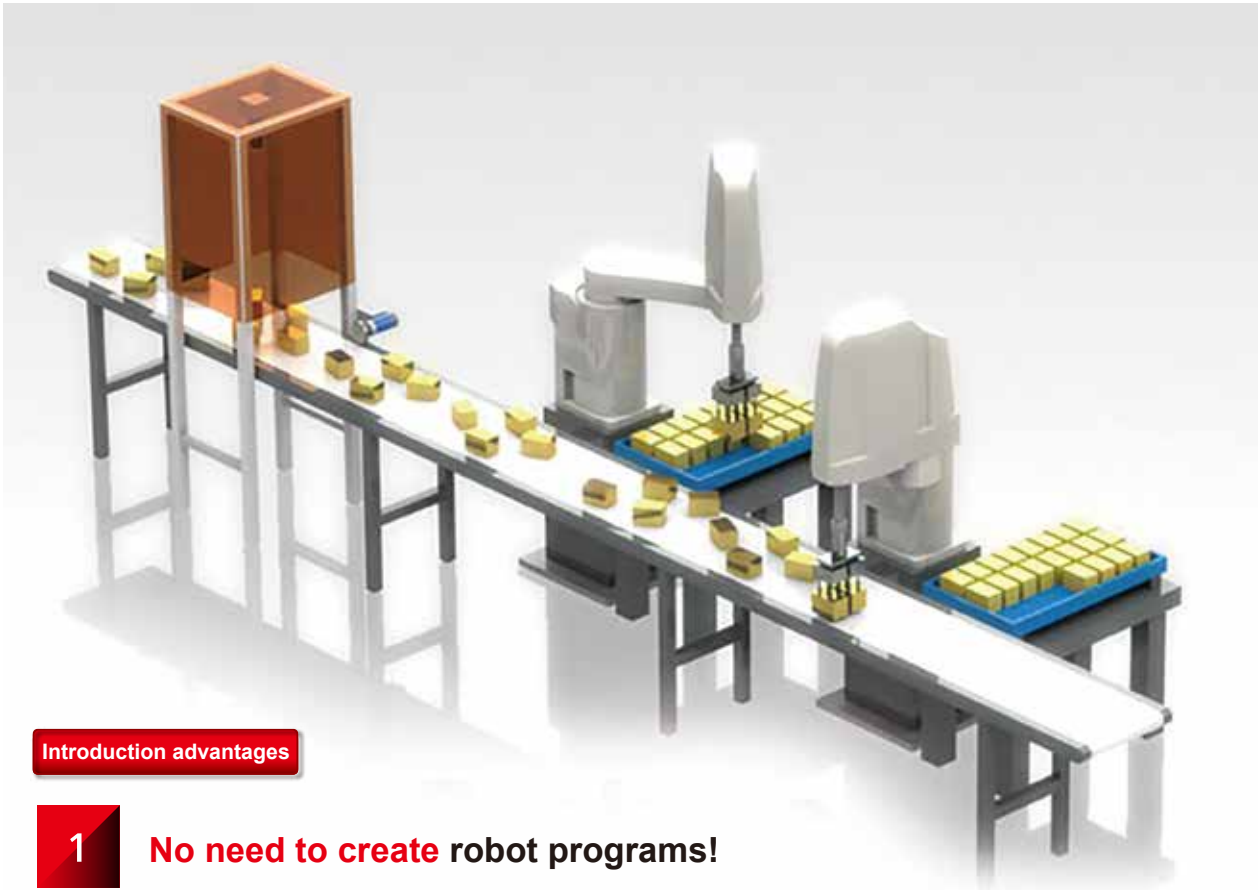

Introduction advantages

- 1 No need to create robot programs!**
- 2 Startup time after the system device installation is reduced by 85%!**
- 3 High-level operations including peripheral-device settings, tracking operation, and ejecting operation can be easily configured with dedicated tools!**

<Reference value>

1. Programming
Time taken for programming: 3 days → 0 hour
(For the tracking application compatible with the basic specifications/layout)
2. Startup time
Precondition: The time taken "from wiring connection to operation check" after the installation/initial settings of robots and installation of conveyors, vision sensors, and encoders
 - 1) Wiring and I/O check: 3 hours → 0.5 hours
 - 2) Connection settings, startup, operation check: 10 hours → 1.5 hours→ **Eleven hours are reduced in total! (13 hours → 2 hours)**

Features

Mitsubishi provides hardware, software, and supporting tools as a package to make designing, programming, and startup on tracking system configuration by customers easy.

Feature 1

No more complex wiring!

- Devices and cables required for tracking are packaged.
- Wiring is completed only by connecting connectors.
- Hands and vacuum solenoid valves for hands have already been installed to robots as default.

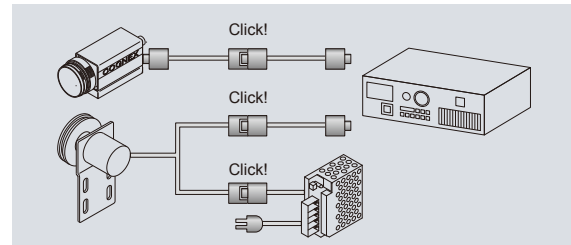

Feature 2

Easy startup with just 5 steps!

- Easy startup with wizard format (interactive format) of dedicated tools (No manuals are required. Just touch buttons following messages shown in the screen.)
- No need to create robot programs
- No more complex communication settings and parameter settings (automatic setting)
- Calibration of conveyors and vision sensors is also completed only by following instructions on the wizard.
- Startup adjustment can be easily performed in the wizard format!

* Teaching operation is required in the calibration screen.



Feature 3

High-accuracy and high-speed operation can be performed!

- Synchronization performance of vision recognition and conveyor speed is improved by the new high-speed input function.
- Dedicated programs optimized for tracking with higher speed and higher accuracy are installed.

Specifications

Basic specifications

Type ^{*1)}		Unit	APR-□TR3FH	APR-□TR6FH	APR-□TR12FH	APR-□TR20FH		
Robot specifications	Robot model name ^{*2)}		RH-3FH5515-● -SA◆◆◆	RH-6FH5520-● -SA◆◆◆	RH-12FH8535-● -SA◆◆◆	RH-20FH10035-● -SA◆◆◆		
	Environmental specifications		General environmental specifications: IP20					
	Maximum reach radius	mm	550	550	850	1000		
	Up/Down stroke	mm	150	200	350	350		
	Connected controller ^{*3)}		CR751-D/Q	CR750-D/Q, CR751-D/Q				
	Power supply specifications	Input voltage range	V	Single phase AC180 to 253		Single phase AC207 to 253, 3-phase AC180 to 253		
		Power source capacity	kVA	0.5	1.0	1.5		
Power supply frequency		Hz	50 or 60					
Standard installation hand specifications (for hand installation specifications) ^{*4)}	Hand		Depends on outline dimensions of hand					
	Hand setting		Single-hand					
	Adsorption pad ⁵⁾ (For operation check)	Manufacturer		SMC				
		Model		ZPR32UN-04-A6 (φ 32)		ZPR32UN-06-A6 (φ 32)		
	Weight	kg	0.4		0.8			
	Piping specification		φ 4 × 2		φ 6 × 2			
	Standard supply pressure (Pressure range)	MPa	0.4 (0.3 to 0.6)					
	Air consumption ⁶⁾	L/min (ANR)	90					
	Vacuum pressure ⁷⁾	kPa	-60					
Adsorption time (reference value)	msec	150 ⁸⁾						
Vision sensor ⁹⁾	Manufacturer		COGNEX					
	Model		EZ-140					
Power supply specifications for PoE-HUB encoder ¹⁰⁾	Voltage	V	AC100 to 240					
	Power consumption	W	60					
	Frequency	Hz	50 or 60					
Applicable system ¹¹⁾	Number of robots	Unit	1 or 2 ¹³⁾					
	Vision sensor	Number of units	Unit	1				
		Installation height	mm	370,450,550 ¹⁴⁾				
	Tracking conveyor	Number of units	Unit	1				
		Width	mm	200,250,300 ¹⁴⁾				
		Maximum speed	mm/sec	300				
	Hand specifications	Setting		Single-hand or double-hand				
		Method		Adsorption pad				
	Applicable workpiece	Number of registrations	Type	4				
		Size	Standard hand (reference value)	mm	55×73×24 ¹⁵⁾			
			Maximum		160×200×100 ¹⁵⁾			
	Weight ¹²⁾	Standard hand (reference value)	kg	0.1 ¹⁵⁾				
	Ejecting operation			Simple transport/Pallet alignment ¹⁶⁾ (MAX: 20 × 20)/Workpiece-picking ejection ¹⁷⁾				
Ambient temperature	°C		5 to 40					
Maximum transport capacity (300mm transport) ¹⁸⁾ (Reference value)	Pieces/min (per 1 robot)		50	80	65	60		

*1) In a model name, □ indicates the number of robots (1 or 2).

*2) In a robot model name, ● indicates a controller type and SA◆◆◆ indicates a special number corresponding to the package used. This product can be used only with this package robot.

*3) When Q type controllers are used, prepare MELSEC-Q series base units, power supply modules, PLC CPUs, and manual pulse generators, create encoder cables, and set parameters with "GX Works2" and "RT ToolBox2".

*4) Hands are supplied with a robot only when the robot has the hand installation specifications.

*5) Select or replace adsorption pads depending on the specifications of workpieces to be transported.

*6) This value may change depending on changes in atmospheric pressure (weather, altitude, etc.) and measuring methods. When the robot is used with double-hand, air consumption will be 90 (L/min) or more.

*7) This value is the detection pressure setting value before shipment.

*8) This value is for one adsorption pad. When the leakage quantity at an adsorption pad is large or when multiple adsorption pads are connected to use on branched pipes, the adsorption time will increase.

*9) Check that workpieces can be recognized with this vision sensor in advance. Lighting is not included in the vision sensor. When lighting is required, prepare it separately by customers. Whether the recognition can be performed or not depends on the usage environment. For details, please contact Mitsubishi.

*10) The power consumption of when the PoE-HUB described in the specifications is used.

*11) The restrictions on the layout placement are as follows:

- 1) Set the conveyor in nearly parallel to the X axis or Y axis of the robot coordinate.
- 2) When two robots are used, set the operating range of each robot so as not to overlap each other.

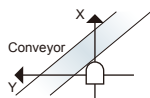

Conveyors cannot be set obliquely against the X axis or Y axis as shown in the left figure.

- 3) At the tracking start point, end point, and limiting point, all range of the conveyor width (workpiece flow width) shall be within the range of the robot movement.

*12) For the maximum load capacity of the robot, refer to "Standard specifications".

*13) When using two robots, set a single operation to both robots. Setting different operations to the robots is prohibited. For example, when Robot 1 transports Workpiece A and B, Robot B cannot transport Workpiece C and D.

*14) The following table shows the relation among the installation height of a vision sensor, conveyor width, and visual field. Decide the installation height of a vision sensor depending on the conveyor width.

Item	Installation height (mm)		
	370	450	550
Conveyor width (mm)	200	250	300
Visual field A × B (mm)	210×280	260×340	310×415

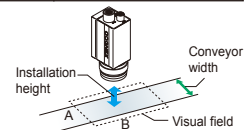

*15) This reference value is based on the conditions of the test conducted by Mitsubishi. The actual value depends on conditions such as the shape and surface state of workpieces.

*16) Pallet alignment can be set to one pallet only. Even though multiple workpieces have been registered, the same pallet shall be set to each workpiece. Align all workpieces to one pallet.

*17) Transportation to a certain position can be set for the workpiece recognition transportation. Pallet alignment cannot be set.

*18) This reference value is based on the conditions of the test conducted by Mitsubishi shown in the following table.

Type	Unit	APR-1TR3FH	APR-1TR6FH	APR-1TR12FH	APR-1TR20FH	
Number of robots	Unit	1				
Vision sensor	Number of units	1				
	Installation height	mm	370	550		
Tracking conveyor	Number of units	1				
	Width	mm	200	300		
	Speed	mm/sec	60	90	75	70
Hand	Number of settings	Single-hand				
	Pad diameter	mm	φ 32			
Workpiece	Number of registrations	1				
	Size	mm	55×73×24			
	Weight	kg	0.1			
	Interval	mm	60			
Ejecting operation	Pattern	Simple ejection				
	Up/Down stroke	mm	25			
Layout		Mentioned in specifications				

Applicable layout

1-robot configuration

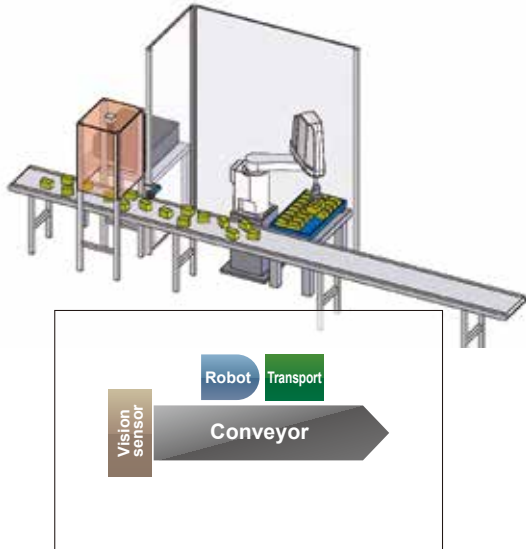

2-robot configuration

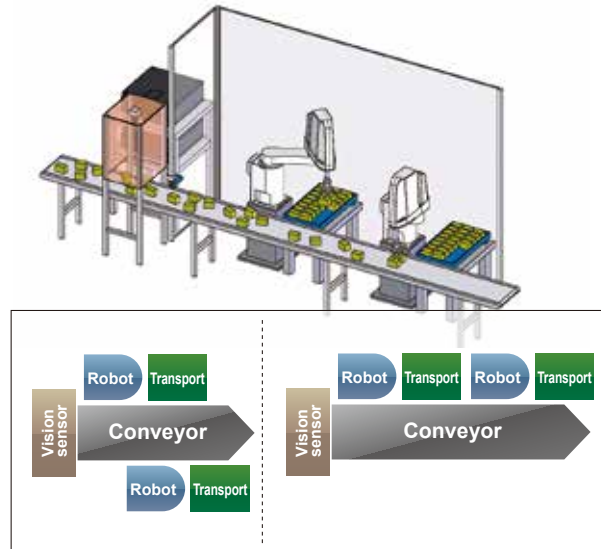

* Consider the maximum load capacity, operating range, and speed of the robot used to decide the layout. For details, refer to the specifications.

Composition of tracking application model name

APR—□TR ●FH ◆ △ — E

a b c d

a □TR The number of robots
 1TR : 1-robot specification
 2TR : 2-robot specification

b ●FH Robot model
 3FH : RH-3FH5515
 6FH : RH-6FH5520
 12FH : RH-12FH8535
 20FH : RH-20FH10035

c ◆ Controller type
 1D : CR751-D controller
 1Q : CR751-Q controller

d △ Hand type
 None: Hand specifications for sink type
 E : Hand specifications for source type
 N : No hand

Package components

No.	Product	Quantity	
		APR-1TR (1-robot specification)	APR-2TR (2-robot specification)
<1>	Packaged robot (robot and controllers)	1	2
<2>	MELFA-Tracking (CD-ROM)	1	1
<3>	Easy setup guide	1	1
<4>	Vision sensor module	1	1
<5>	Encoder module	1	1
<6>	5VDC power supply set (only for D type controllers)	1	—
	24VDC power supply set	—	1
<7>	Vision cable	1	1
<8>	Vision I/O cable	1	1
<9>	Encoder cable	1	—
		—	1
<10>	Calibration sheet	1	1
<11>	Encoder distribution set (only for D type controllers)	—	1

When Q type controllers are used, prepare manual pulse generators and create encoder cables.

<1> Packaged robot (robot and controllers)



(Hand and vacuum unit: already installed)
* The above robot has hand installation specifications.

<2> MELFA-Tracking (CD-ROM)



<3> Easy setup guide



<4> Vision sensor module



<5> Encoder module

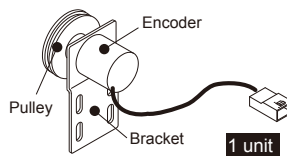

<6> 5VDC power supply set: 1-robot specification



24VDC power supply set: 2-robot specification



<7> Vision cable



<8> Vision I/O cable



<9> Encoder cable

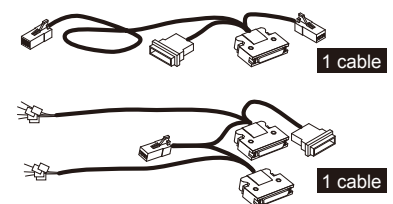

<10> Calibration sheet

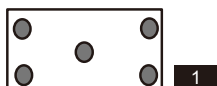

<11> Encoder distribution set

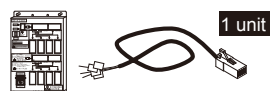

System configuration example (one robot, robot controller CR750-D)

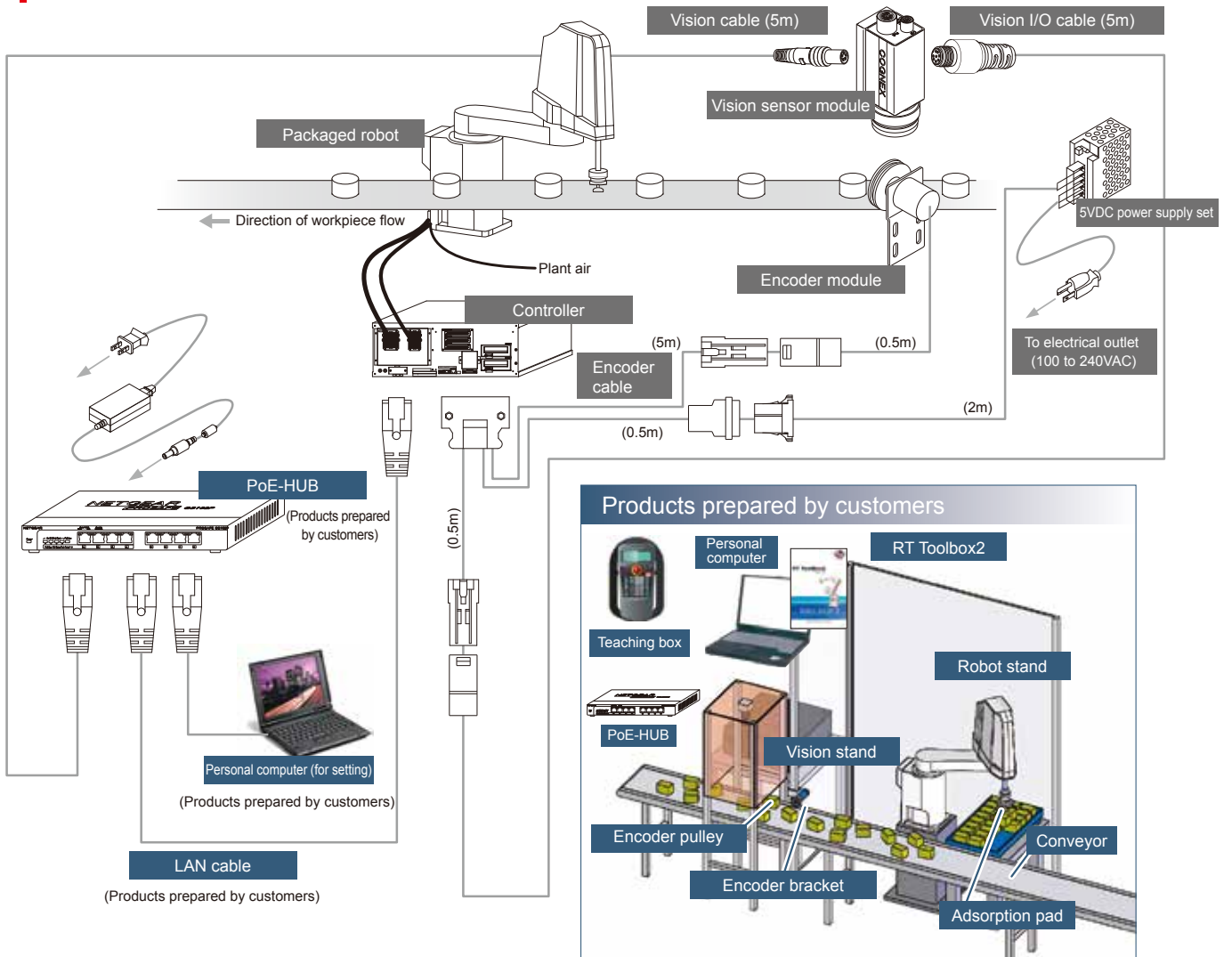

* Adsorption pads, encoder pulleys, and encoder brackets are supplied for operation check.
 * For any systems that require additional products other than the above, prepare the products yourself.
 * For details of T/B and RT2, refer to the F series catalog.

Outline dimensions of hand (Hand installation specifications only)

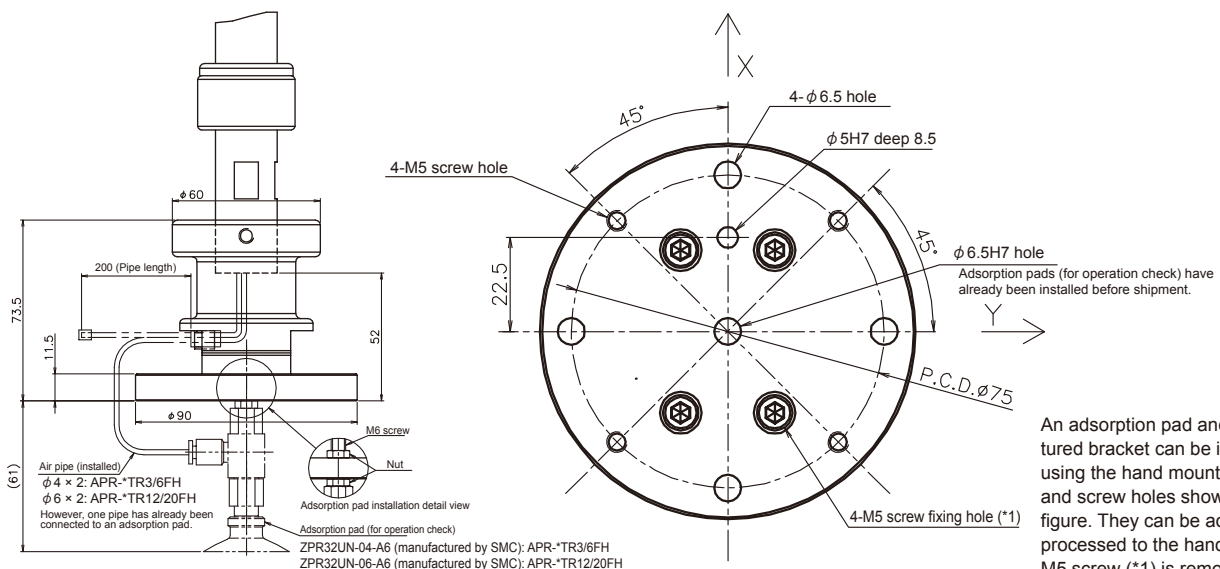

An adsorption pad and manufactured bracket can be installed using the hand mounting holes and screw holes shown in this figure. They can be additionally processed to the hand when the M5 screw (*1) is removed.

► Processing Machine Loading Application

This application facilitates the configuration of a loading/unloading system for processing machines in which a Mitsubishi CNC numerical control devices has been installed.

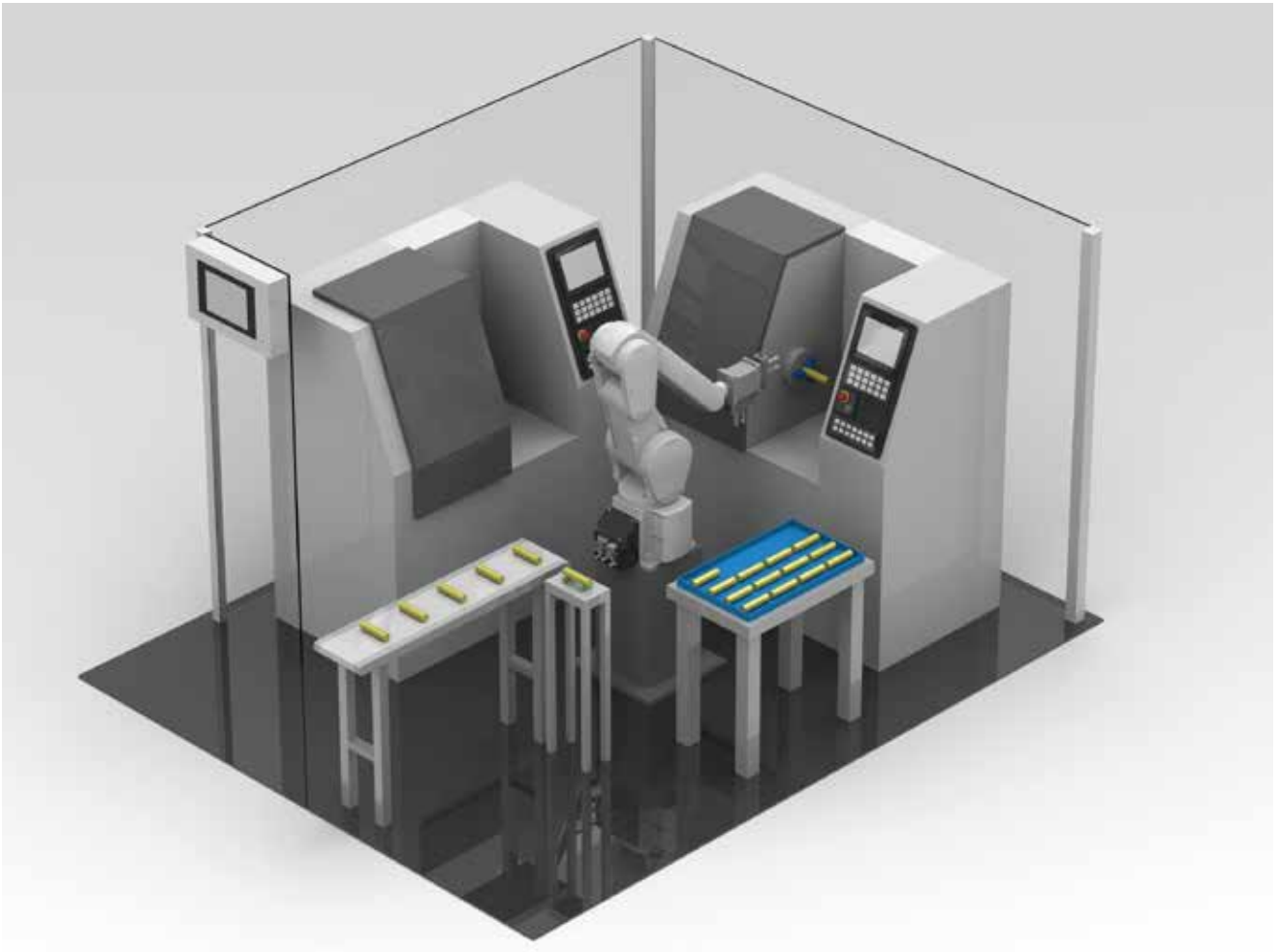

Introduction advantages

- 1** No need to create robot programs!
- 2** User-friendly wizard screens shorten the startup time by 80%!
- 3** The system operation can be started smoothly with the various screens pre-installed on the operation box!

Features

Mitsubishi provides hardware, software, and supporting tools as a package to make designing, programming, and startup on the configuration of a loading/unloading system easy for customers.

Feature

1

Simple wiring design! Easy wiring work!

- CNC numerical control devices and a robot can be connected via CC-Link, and an operation box and the robot can be connected with a connector.
- A parallel I/O interface for connecting signals of peripheral devices has been installed to a robot controller.

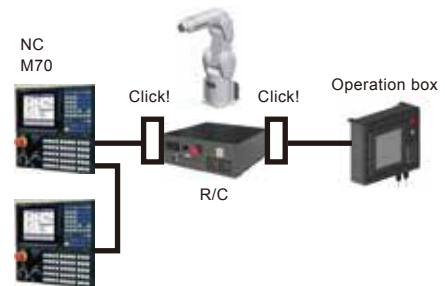

Feature

2

Processing machine loading-dedicated programs and interface functions facilitate easy setting and startup!

- As soon as an operation box is connected, the system can be started!
(The system can be started by using the dedicated startup software, MELFA-Machine Loading!)
- There is no need to configure communication settings, I/O assignment, and parameter settings of CNC devices and robots! (automatic setting)
- A necessary program is automatically selected by the selection type menu!
(Robot programs have already been installed.)
- Teaching operations can be performed by following the wizard.

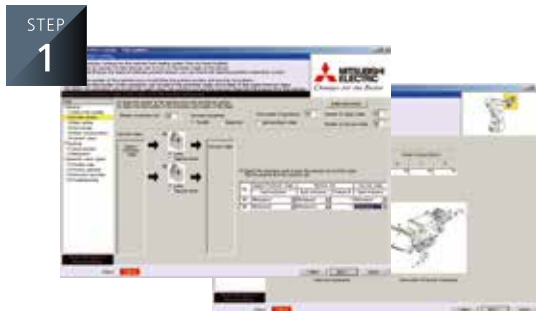

Initial setting: System/hand setting screen



Teaching: Stage/processing machine teaching screen

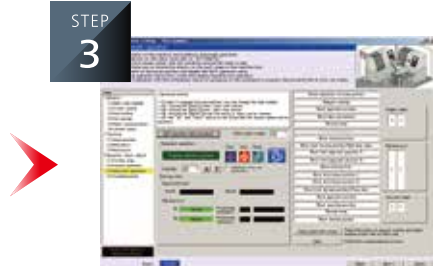

Operation check and adjustment: Process operation/automatic operation screen

Startup is completed!!

Feature

3

A system that has improved the compatibility of robots and CNC devices can be operated!

- System central control display of maintenance information (including coordinates and tool lives) of a processing machine (CNC) in a system
- The robot status can be displayed and the robot can be operated on the same system screen.



Processing machine monitor screen



Robot manual operation screen

Specifications

Basic specifications

Type		Unit	APR-1ML4FM /4FLM	APR-1ML7FM/ 7FLM /7FLLM	APR-1ML13FM /13FLM	APR-1ML20FM				
Robot specifications	Robot model name ^{*1)}		RV-4FM/4FLM -●-SA◆◆◆◆	RV-7FM/7FLM/7FLLM -●-SA◆◆◆◆	RV-13FM/13FLM -●-SA◆◆◆◆	RV-20FM -●-SA◆◆◆◆				
	Protection grade of robot		IP67							
	Load capacity ^{*2)}	kg	4	7	13	20				
	Maximum reach radius	mm	515	649	713	908	1503	1094	1388	1094
	Connected controller		CR750-D/CR751-D							
Protection grade of controller		IP20 ^{*3)}								
Operation box specifications	Size	mm	H290 × W460 × L140 (protrusions excluded)							
	Protection grade (IP)		IP54							
	Interface	Touch panel		10.4" VGA [640 × 480], TFT color liquid crystal (GOT2000 series)						
		Others		Emergency stop button × 1						
	Screen		1) Main screen 5) Production management	2) System monitor 6) Robot manual operation	3) Processing machine monitor 7) Robot maintenance	4) Stock information 8) Settings				
	Connection		Between a robot and operation box: External emergency stop cable (7m), LAN cable (7m)							
	Weight	kg	10							
	Power supply specifications	V	Single phase AC180 to 253	Single phase AC 207 to 253, three-phase AC 180 to 253						
Power source capacity	kVA	1.1	2.1	3.1						
Applicable system	Number of robots	Unit	1							
	CNC ^{*4)}	Type	Mitsubishi CNC M70V series, M80V series							
		Number of units	Unit	1 or 2						
		Necessary option		CC-Link option						
	Processing machine	Type	Small lathe, tapping center							
	Hand ^{*5)}	Hand configurations	Double-hand							
		Drive method	Air grip							
	Workpiece	Size	mm	Supported sizes vary depending on the shape of grip jaws and a hand to be prepared by users.						
		Number of steps ^{*6)}		5						
	Layout	Applicable layout (reference) ^{*7)}		One processing machine, one robot Two processing machines (face-to-face arrangement), one robot Two processing machines (L-shape arrangement), one robot						
		Workpiece feed stage		Conveyor or pallet						
Workpiece ejection stage			Conveyor or pallet							
Workpiece transport pattern ^{*8)}			When using two processing machines, select a parallel or sequential transport pattern.							

*1) In a robot model name, ● indicates a controller type and SA◆◆◆◆ indicates a special number corresponding to the package used. This product can be used only with this package robot.

*2) The weight of a workpiece that can be loaded under the limitation of a mechanical interface having a downward attitude

*3) From a consideration of the installation environment of a controller, using an optional protective box is recommended.

*4) This application links robots and CNC devices and operates them. Thus, set CC-Link parameters and create a ladder program for CNC devices, and input and output signals from a processing machine to robots.

A CD for installing MELFA-Machine Loading will be supplied to each customer. This CD includes sample parameter data for setting parameters and creating a ladder program for CNC devices and sample ladder programs for inputting and outputting signals. Refer to the manuals of CNC devices to set parameters and create a ladder program for CNC devices.

*5) Prepare a hand by customers. Design a hand depending on the robot or controller of this package or customer's system.

*6) For details of the number of steps, refer to the "Instruction manual".

*7) For reference diagrams of system layouts, refer to the "Instruction Manual".

*8) For details of workpiece transport patterns, refer to the "Instruction Manual".

Applicable transport patterns

This application package is applicable to the layout of one processing machine or two processing machines per a robot. Applicable processing machines are lathes and tapping centers. The following shows system examples.

1) When using one processing machine

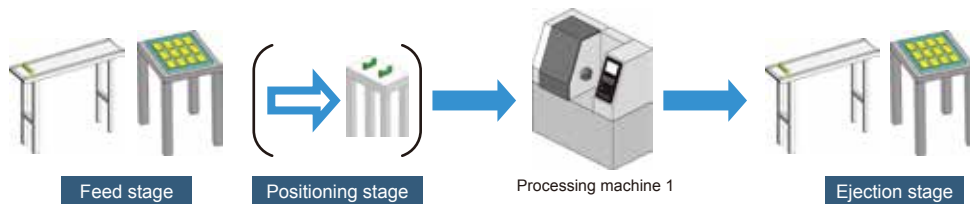

2) When using two processing machines

a) Parallel transport

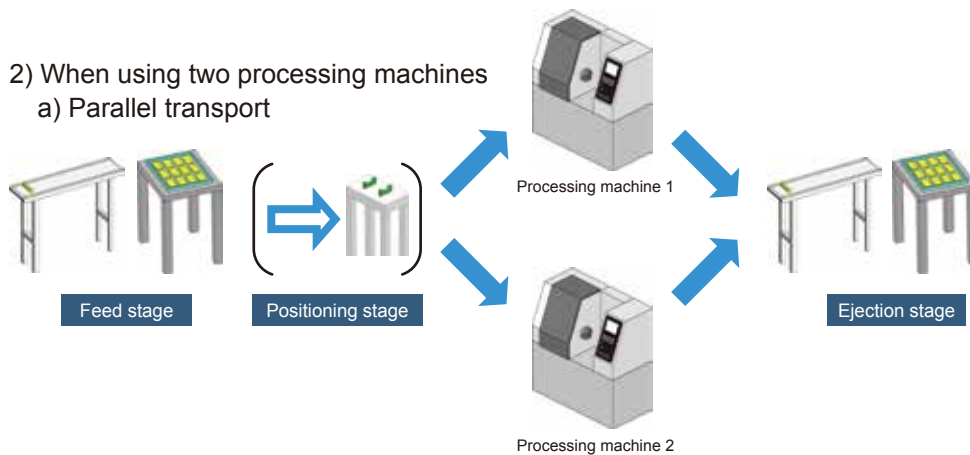

b) Sequential transport

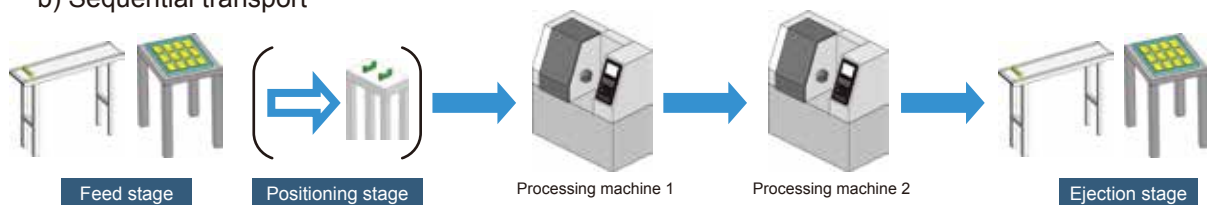

Model configuration of the processing machine loading application

APR-1ML - S11

a b c

a ● Robot model
 4FM : RV-4FM
 4FLM : RV-4FLM
 7FM : RV-7FM
 7FLM : RV-7FLM
 7FLLM: RV-7FLLM
 13FM : RV-13FM
 13FLM: RV-13FLM
 20FM : RV-20FM

b ◆ Controller type
 1D: CR751-D controller

c △△ Type of the hand or other I/O signals
 N : Sink type
 NE: Source type

Package components

No.	Product	Quantity
<1>	Package robot (main unit, controller*1)	1
<2>	MELFA-Machine Loading (CD-ROM)	1
<3>	Easy setup guide	1
<4>	Operation box	1
<5>	LAN cable	1
<6>	Emergency stop cable	1
<7>	CC-Link cable	1
<8>	Power connector for the operation box	1
<9>	Power cable for the robot controller	1 (one of the cables)

<1> Packaged robot /controller*1)



1 each

*1) CC-Link interface, a parallel I/O interface has been installed

<2> MELFA-Machine Loading (CD-ROM)



1

<3> Easy setup guide



1

<4> Operation box



1 unit

<5> LAN cable



1 cable

<6> Emergency stop cable



1 cable

<7> CC-Link cable



1 cable

<8> Power connector for the operation box

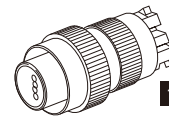

1 connector

<9> Power cable for the robot controller



One of the cables

Outline dimensions of an operation box

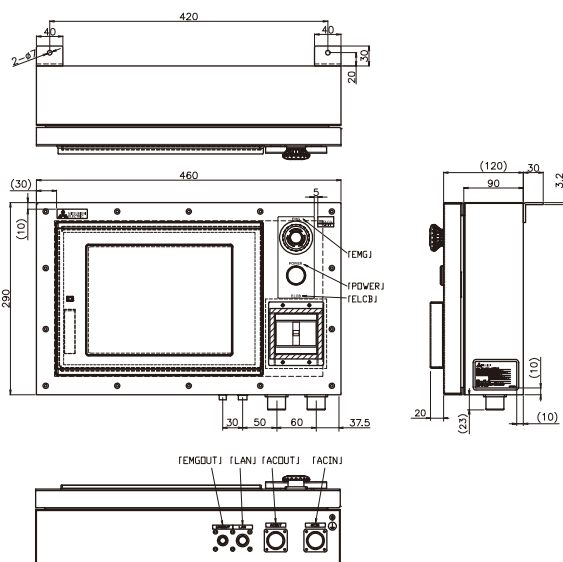

Entire configuration

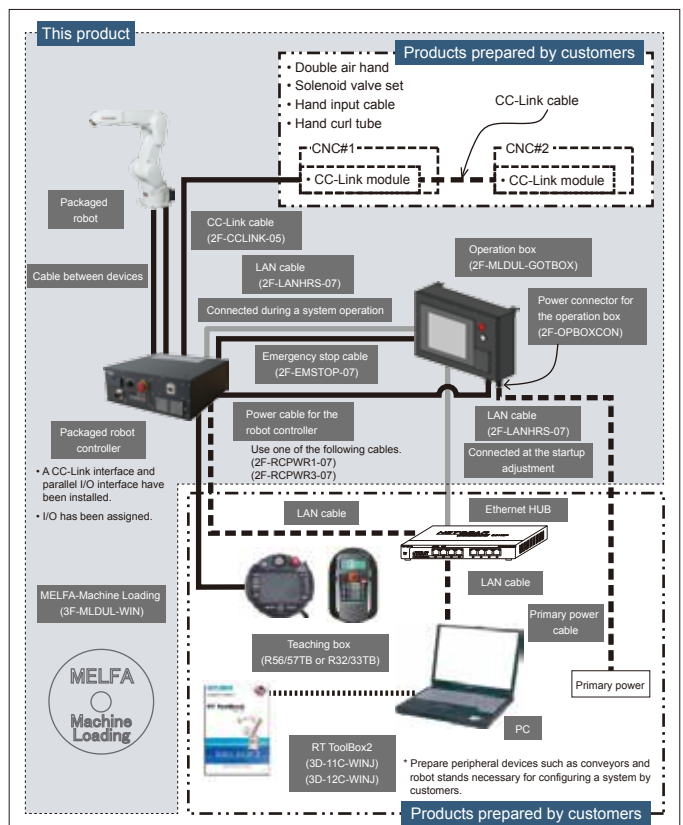

System configuration

Products prepared by customers

(The following image diagram is for when two processing machines have been used.)

Prepare devices necessary for configuring a processing machine loading system, robot peripheral devices, and a personal computer to start up the system.

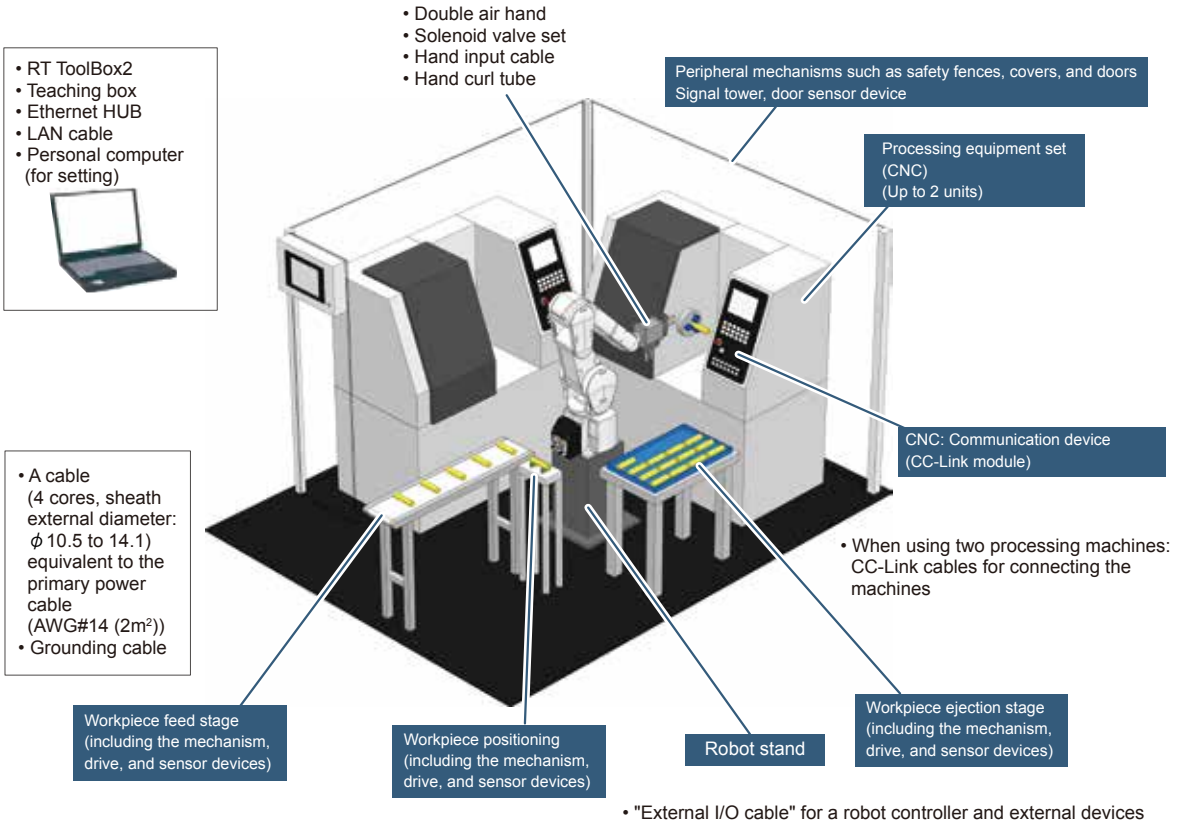

Applicable layout

Lathe

One processing machine



Two processing machines

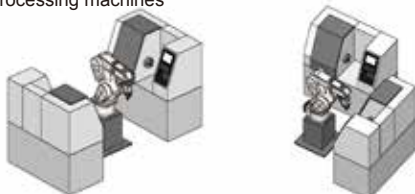

Tapping center

One processing machine



Two processing machines

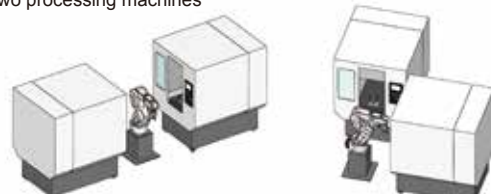

► Force-sense Applications

Techniques and know-how are added to MELFA robots to achieve the automation of force-sense operations such as assembly, insertion, and inspection.

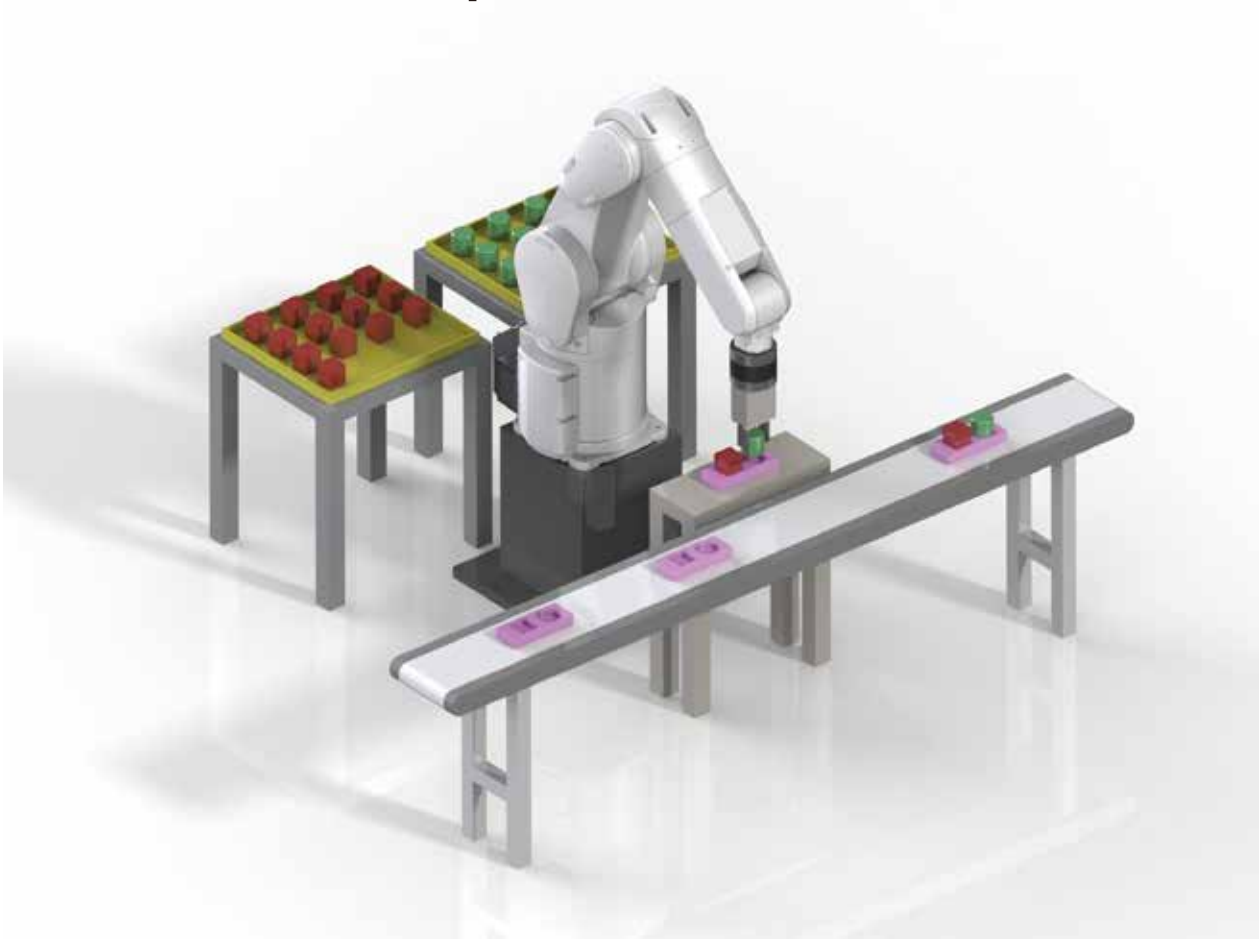

Introduction advantages

1

No need to create force-sense programs!

2

The startup time of force-sense operations can be **reduced by 80%!**

3

Operations including force sensor settings and force-sense application operations can be **easily configured with dedicated tools!**

Features

Mitsubishi provides hardware, software, and supporting tools as a package to make designing, programming, and startup on the configuration of a force-sense application system easy for customers.

Feature 1

No more complex initial setting!

- Wiring for a force sensor is completed only by connecting connectors.
- The initial setting of a force sensor is completed only by pressing one button.

Initial setting screen of the force-sense application software (RT-ToolBox2 add-on)



Initial setting parameter for force sensors

- Force-sense IF recognition
- Coordinate system
- Attachment position
- Permissible value
- Corrected limit value
- Setting number
- Mechanical number

Connection example

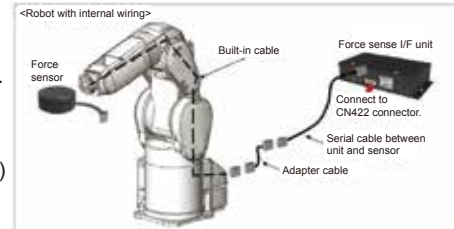

Feature 2

Difficult operations that use force sensors can be created easily!

- Operation sub programs that use a force sense can be easily created on a dedicated screen.

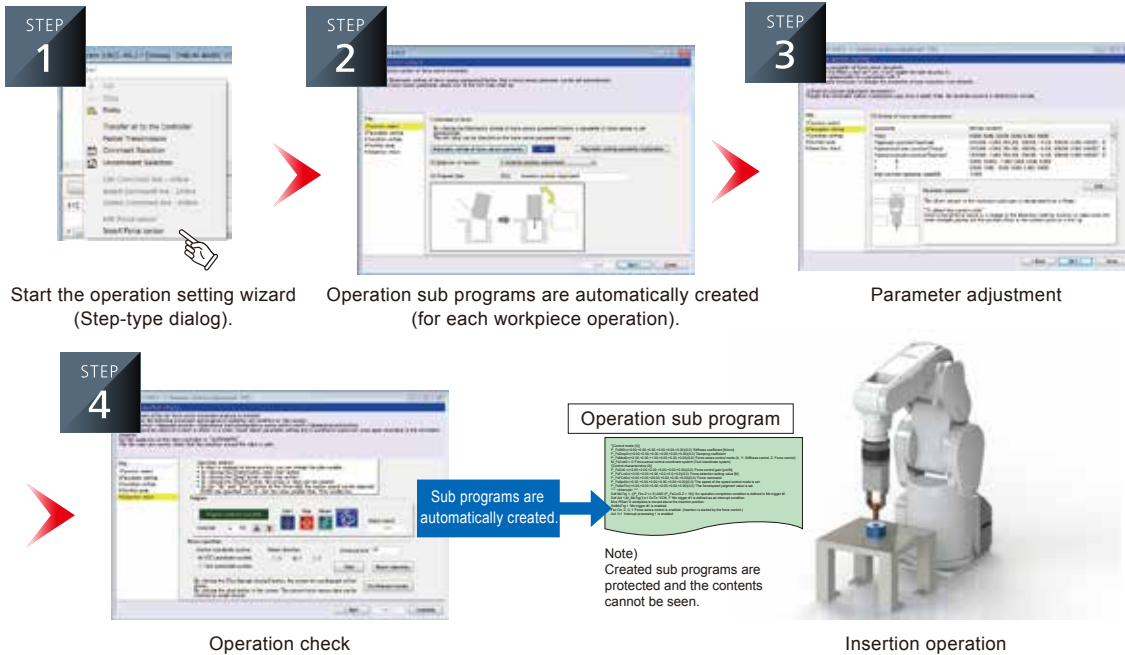

Feature 3

No more complex adjustments!

- Complex programming of the force-sense operation parameters can be easily adjusted on a dedicated screen.

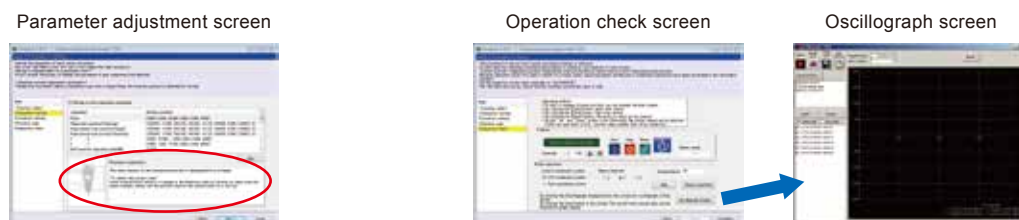

Initial values have already been set to necessary parameters. Parameters are explained with user-friendly diagrams.

The oscillograph screen can be started from the operation check screen.

Users can check operations by seeing force-sense data in an oscillograph.

Specifications

Basic specifications

Type		Unit	AP10-AFS2F	AP10-AFS2L	AP10-AFS4/5F	AP10-AFS4/5L	AP10-AFS7/8F	AP10-AFS7/8L
Robot specifications	Robot model name ¹⁾		RV-2F-●S◆ ⁴⁾	RV-2FL-●S◆ ⁴⁾	RV-4F-●S◆	RV-4FL-●S◆	RV-7F-●S◆	RV-7FL-●S◆
	Environmental specifications		General environmental specifications: IP20					
	Maximum reach radius	mm	504	649	515	649	713	908
	Load capacity	kg	Maximum 3 (Rating 2)		Maximum 4 (Rating 4)		Maximum 7 (Rating 7)	
	Connected controller		CR750-D/Q, CR751-D/Q					
	Power supply specifications	Input voltage range	V	Single-phase AC180 to 253				Single phase AC 207 to 253 Three-phase AC180 to 253
Power source capacity		kVA	0.5		1.0		2.0	
Power supply frequency		Hz	50 or 60					
Force sensor specifications	Rated load	Fx, Fy, Fz	N			200		
		Mx, My, Mz	Nm			4		
	Max. static load	Fx, Fy, Fz	N			1000		
		Mx, My, Mz	Nm			6		
	Breaking load	Fx, Fy, Fz	N			10000		
		Mx, My, Mz	Nm			300		
	Minimum control force	Fx, Fy, Fz	N			0.3		
		Mx, My, Mz	Nm			3		
	Consumption current	mA	200					
	Weight (sensor unit)	g	360					
External dimensions	mm	φ 80×32.5						
Protective structure		IP30						
Force sensor interface unit specifications	Interface	RS-422	ch		1 (for connecting sensors)			
		SSCNETIII	ch		1 (For connecting robot controllers and additional axis amplifiers)			
	Power supply	Input voltage	Vdc		24±5%			
		Power consumption	W		25			
	External dimensions	mm	225(W)×111(D)×38(H)					
	Weight	kg	Approx. 0.8					
Structure		IP20 (Panel installation, open type)						
Operations settable with the force-sense application software ^{2),3)}			1) Insertion attitude adjustment operation, 2) Push-in operation, 3) Insertion operation, 4) Contact position detection					

¹⁾ In a robot model name, ● indicates a controller type and S◆ indicates a special number corresponding to the package used. This product can be used only with this package robot.

²⁾ Set these operation conditions using "MELFA-Force Sense Plus" (dedicated screen on RT ToolBox2) and add the conditions to a program.

³⁾ Check whether the operations can be actually performed or not using actual workpieces in advance.

⁴⁾ Force sensor cables will be exteriorly wired.

Entire configuration

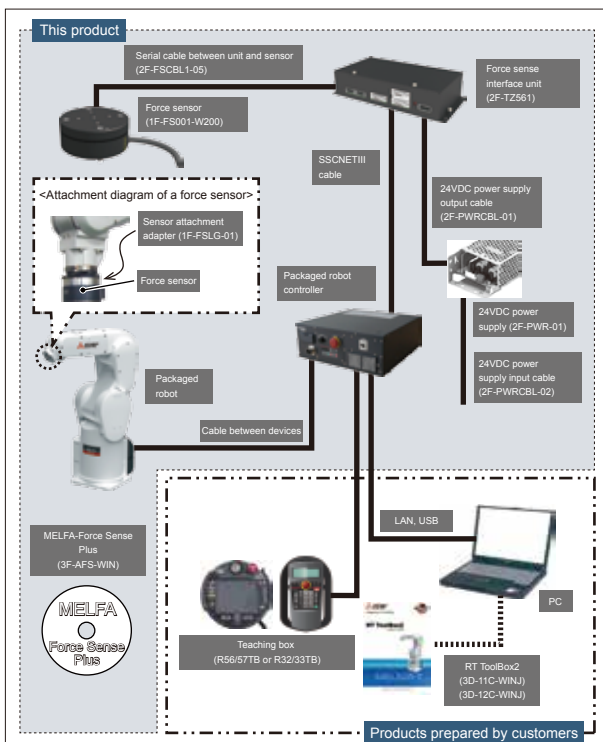

* Prepare hands and peripheral devices by customers.

Composition of a force-sense application model name

AP10-AFS0 ● ◆ - E0
a b

a ● Robot model

2F: RV-2F
2L: RV-2FL
4F: RV-4F-SH03
4L: RV-4FL-SH03
5F: RV-4F-SH04
5L: RV-4FL-SH04
7F: RV-7F-SH03
7L: RV-7FL-SH03
8F: RV-7F-SH04
8L: RV-7FL-SH04

b ◆ Controller type

BD: CR751-D controller
BQ: CR751-Q controller

Insertion adjustment

Operation

The insertion attitude of a gripped workpiece is positioned on an insertion position by getting up the workpiece along the edge of the insertion position.

Application

This operation is effective for moving workpieces that are relatively less chamfered or having a small mating tolerance.

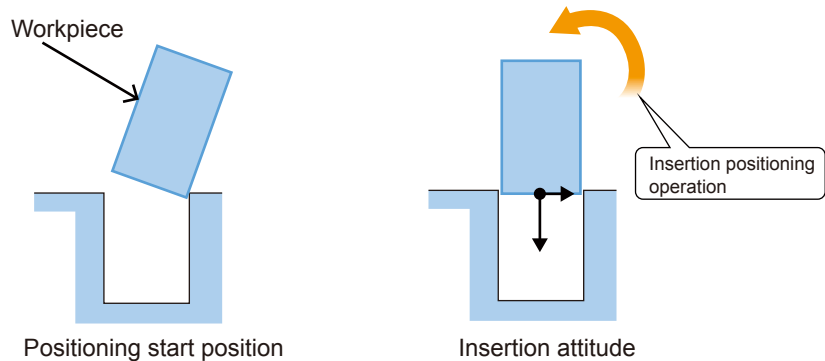

Push-in operation/insertion operation

Operation

A workpiece is inserted by adding a force in a given direction.

- Push-in operations such as engaging workpieces can be performed by setting a force strength and direction.
- In an insertion operation, a workpiece can be inserted without being caught during the insertion by setting a periodic travel amount (vertical movement, rotation, inclination) during operation.

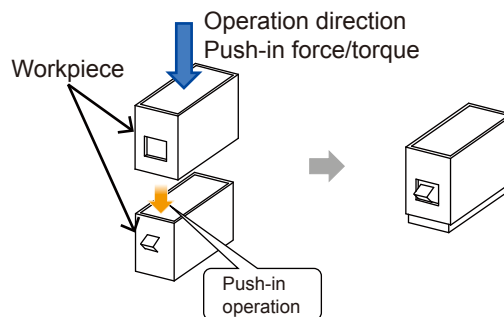

Application

- Pushing snap mechanism parts with a constant force
- Pulling inspections of assembly parts
- Engagement of parts having tightening margins
- Engagement of parts having small mating tolerances
- Operation to avoid the friction of engagement parts
- Shaft diameter inspection with a master gauge

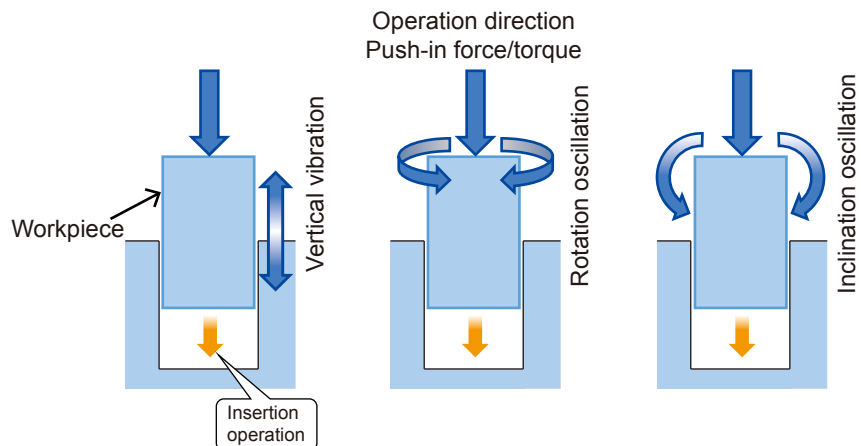

Contact position detection

Operation

While a force is being monitored, a workpiece is moved in a given direction from the original attitude and will stop at a position where the workpiece contacts with something.

- The position of a workpiece can be detected by referring to the current position of the robot after the stop.

Application

- Inspecting part grip positions
- Detecting the positions of peripheral assembly jigs
- Positioning or phase focusing of parts

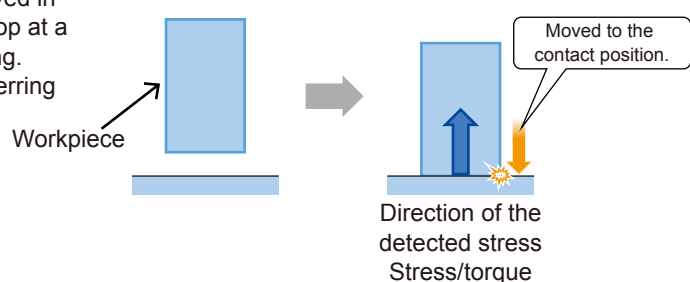

► Deburring/Polishing Application Package

Easily creates a machining path of deburring /polishing and performs machining!
On-site operators can automate their teaching process with rough teaching using a master workpiece and tools.

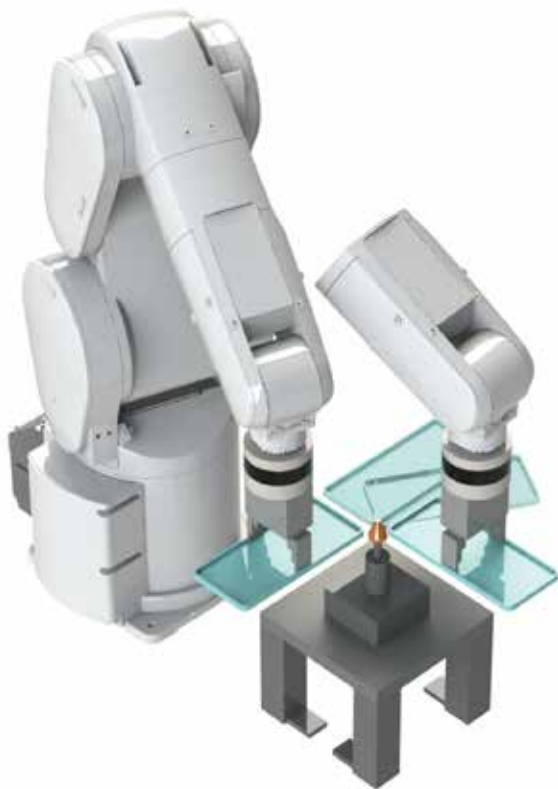

Introduction advantages

- 1 On-site operators can create a machining path **at their sites!**
- 2 Teaching can be **easily performed** with the simple configuration!
- 3 Compared with the offline teaching that uses an actual workpiece, the startup time has **decreased by 80%!**

Feature

Mitsubishi provides hardware, software, and supporting tools as a package to make designing, programming, startup, and adjustment required for the deburring/polishing operation with a robot easy for users.

Feature 1

No more complex wiring!

- Devices and cables required for deburring/polishing are packaged.
- Wiring is completed only by connecting connectors.
- Option cables have already been connected to the main unit!

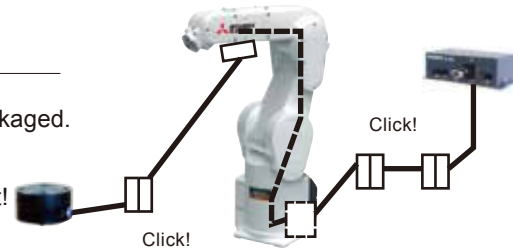

Feature 2

Both [workpiece gripping] and [tool gripping] with a robot can be performed!

- Easy startup with wizard format (interactive format) of dedicated tools (No manuals are required. Just touch buttons following messages shown in the screen.)
- Operation commands (Deburring/polishing)
- Pushing methods (tool coordinate system/orthogonal coordinate system/stiffness)
- Easy setting of force sensor parameters
- Detailed machining commands such as push amount, the number of machining times, approach run/overrun, etc.

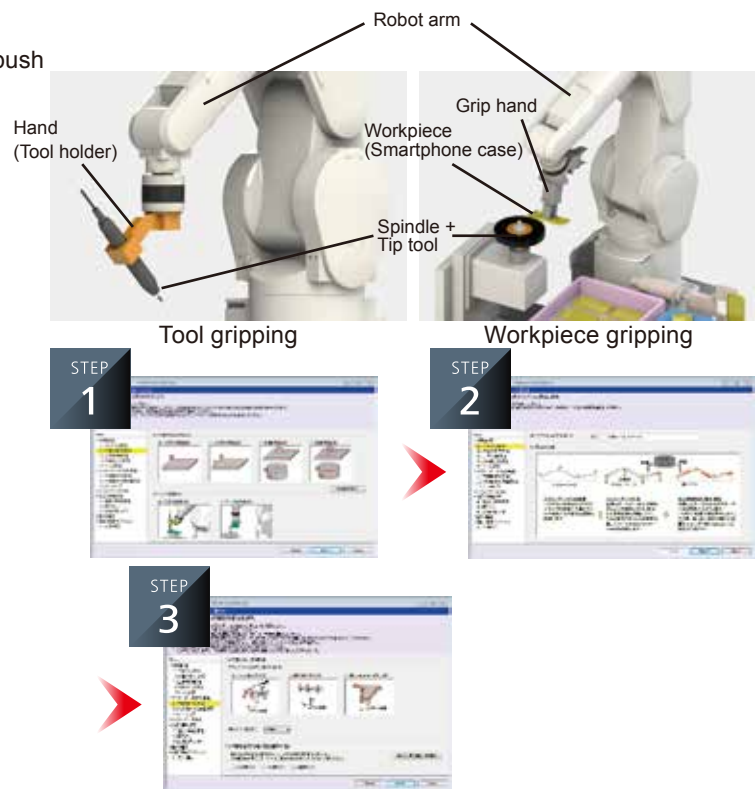
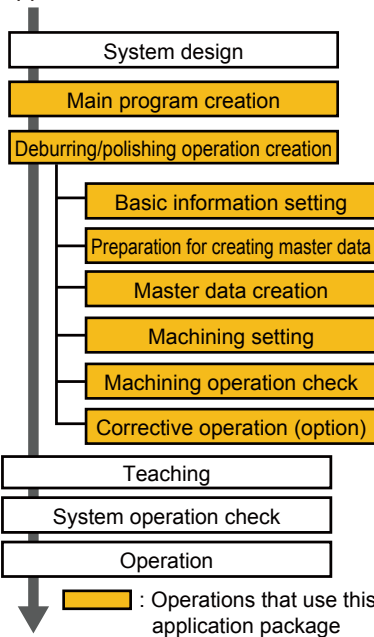

Feature 3

New functions including know-how required for deburring/polishing operations have been implemented!

- Rough teaching using a master workpiece and a force sensor hand automatically creates a machining path. Prevents a short-period stop caused by deceleration when the maximum load is detected at machining. The wear amount of a tip tool is detected for the machining path correction function.

Specifications

Basic specifications

Type ^{*1)}		Unit	AP10-BRP07F	AP10-BRP07L	AP10-BRP08L	AP10-BRP03F	AP10-BRP03L	
Robot specifications	Robot model name		RV-7FM -▲-S◇	RV-7FLM -▲-S◇	RV-7FLLM -▲-S◇	RV-13FM -▲-S◇	RV-13FLM -▲-S◇	
	Environmental specifications		Protection specification: IP67					
	Maximum reach radius	mm	713	908	1503	1094	1388	
	Load capacity	kg	Maximum 7 (Rating 7) ^{*2)}			Maximum 13(Rating 12) ^{*2)}		
	Connected controller		CR750-D/Q,CR751-D/Q ^{*3)}					
Force sensor specifications	Rated load	Fx,Fy,Fz	N	1000				
		Mx,My,Mz	Nm	30				
	Minimum control force	Fx,Fy,Fz	N	Minimum 0.3				
		Mx,My,Mz	Nm	Minimum 0.03				
	Weight (sensor unit)	g	580					
	External dimensions	mm	φ90×H40					
	Protective structure		IP30					
Force sensor interface unit specifications	Interface	RS-422	ch	1(for connecting sensors)				
		SSCNETIII	ch	2(For connecting robot controllers and additional axis amplifiers)				
	External dimensions	mm	225(W)×111(D)×38(H)					
	Weight	kg	Approx. 0.8					
	Structure		IP20(Panel installation, open type) ^{*4)}					
Dust-proof cover	Dust-proof cover		Dust-proof cover for force sensor					
	Protective structure		IP50					
Tool	Spindle		MS01-R03 (MINITOR CO.,LTD) and EMS-3060A (NAKANISHI INC.) are supposed to be used.					
	Tip tool		Tool that can be used for the spindle and material to be machined					
	Connection to R/C		D type controller: Connection via the parallel I/O interface (purchased separately) Q type controller: Connection via an I/O module of the iQ Platform-compatible PLC.					
	Control		Selection of the spindle controller control (startup, stop, error check, etc.) with I/Os With the spindle controller specifications, tools can be controlled by a robot controller using a general-purpose I/O module. (Create a user program.)					
Peripheral device		Robot stand, workpiece positioning/loading/unloading mechanism, dust collector, safety cover, etc.: Separately created by users						
Functions of the application package	Machining path creation function		Automatically creates a machining path with rough teaching using a master workpiece and acquiring force sensor contact position data.					
	Machining condition setting		Detailed machining commands such as operation commands (deburring/polishing), pushing methods (tool coordinate system/orthogonal coordinate system/stiffness), easy setting of force sensor parameters, push amount, the number of machining times, and approach run/overrun					
	Machining error processing function		Prevents a short-period stop caused by deceleration when the maximum load is detected at machining.					

*1) In a robot model name, ▲ indicates a controller type and ◇ indicates a special number corresponding to the package used. This product can be used only with this package robot.

*2) The maximum weight of a workpiece that can be loaded under the limitation of a mechanical interface having a downward attitude (±10° from the vertical line). For the shape, size, and weight of the tool holder and the workpiece grip hand designed by users, check that all these specifications including the machining reaction force are within the specification values of the load capacity/allowance moment of the robot and force sensors.

*3) The protection grade of a robot controller is IP20.

*4) The machining quality is not guaranteed with this application package.

Select the optimal tools (spindle, tip tool) and set the optimal machining conditions (speed, position, push amount, the number of machining times).

*5) The ambient temperature of the location where robots and controllers are installed is 0 to 40°C. Always use them within the temperature range.

*6) The relative humidity of the location where controllers are installed is 45 to 85%. Always use them within the humidity range.

*7) Dry type deburring/polishing operations around robots are supposed to be performed. Do not perform wet type deburring/polishing operations (including spraying and using cooling liquid/lubricating liquid/mold release agent).

*8) Prevent dust from entering the unit as necessary. For example, store the unit inside the robot stand with covers or a control panel.

Entire configuration

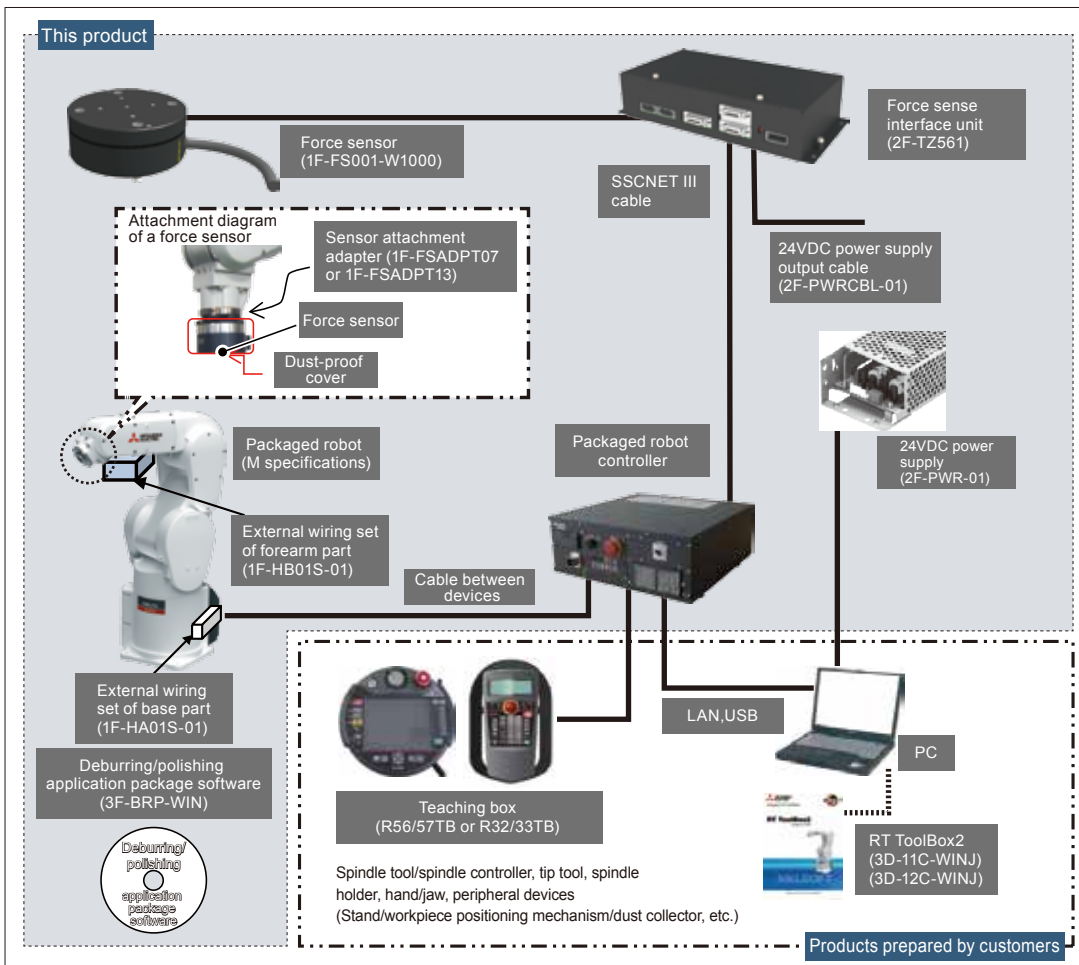

Composition of model name

A10—BRP0 ■ ■ ▲ ▲ — E0

a b

a ■ ■ Robot model

- 3F :RV-13FM
- 3L :RV-13FLM
- 7F :RV-7FM
- 7L :RV-7FLM
- 8L :RV-7FLM

b ▲ ▲ Controller type

- AD :CR750-D controller
- AQ :CR750-Q controller
- BD :CR751-D controller
- BQ :CR751-Q controller
- CD :CR750-D controller(CE standard)
- CQ :CR750-Q controller(CE standard)
- DD :CR751-D controller(CE standard)
- DQ :CR751-Q controller(CE standard)

■ Safety Solution

- Cooperative operation of humans and robots to further improve the productivity -

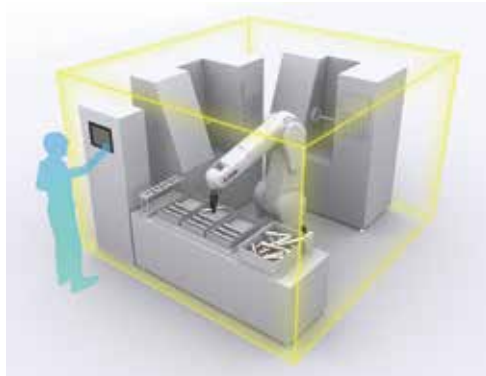

- The increased safety compliant with the international safety standards enables the cooperative operation.
- It is possible to continue the production without the need to stop the system even when a person enters or exits the robot operation area.

(The operator operation area and robot operation area are separated each other with a monitoring plane for safety.)

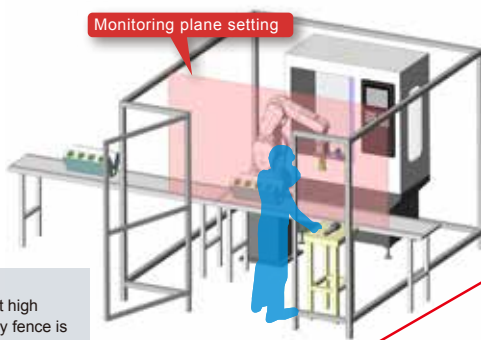

<Explanation>

- The robot operates at high speed while the safety fence is close.
- While the safety fence is open, the robot continues its operation at low speed inside the monitoring plane.

The operator can perform inspection inside the safety fence and outside the monitoring plane.

(An operator and a robot access the shared operation area alternately, allowing for cooperative operation with a robot and an operator.)

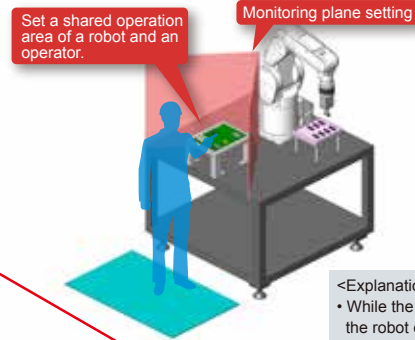

<Explanation>

- While the operator is on the mat, the robot cannot enter the shared operation area.
- While the operator is not on the mat, the robot operates inside the shared operation area.

(Area sensors secure the safety without safety fence.)

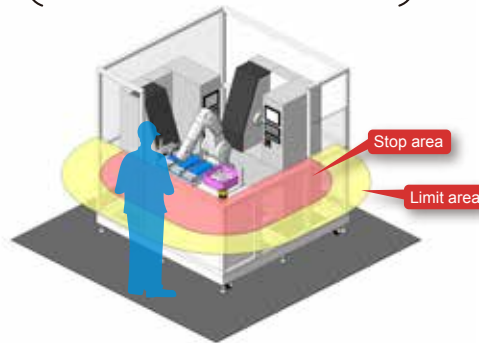

<Explanation>

- When the operator enters the limit area, the robot operation speed is limited.
- Further, the operator approaches to the stop area, the robot stops its operation.

Item	Description	Remarks
STO function	Electronically shuts off the power to the motor of the robot.	Corresponds to the Stop category 0 of IEC 60204-1
SS1 function	Controls and decelerates the motor speed of the robot.	Corresponds to the Stop category 1 of IEC 60204-1
SLS function	Monitors the TCP speed not to exceed the monitoring speed.	Complies with EN61800-5-2
SLP function	Monitors a specified monitoring position not to exceed the position monitoring surface.	Complies with EN61800-5-2
STR function	Monitors the torque feedback not to exceed the allowable torque range.	Complies with EN61800-5-2

For further advanced applications

3D vision sensor

Realizes supply of discretely placed parts

The use of 3D vision sensors realizes supply of discretely placed parts without dedicated trays and part feeders, reducing part supply work.

Realizes high-speed bin picking using our unique technology

Eliminates the need to register the 3D model of a target workpiece, shortening the startup time.

3D modeling is no longer required - this sensor changed the common sense of vision sensors!

3D vision sensors changed the common sense of vision sensors and realized bin picking (picking of discretely placed parts), eliminating the need to register the shape of workpieces. With a bit of information required for gripping (hand jaw width, jaw dimensions, adsorption pad size etc.), this hand grips various workpieces, shortening the startup time.

*Some other devices such as 2D vision sensors are required for final positioning.

* When 3D and 2D vision sensors are used together, adjust 2D vision sensors.

Applicable to multiple recognition methods

Users can use different recognition methods, such as model-less recognition or model matching, for their applications.

Please contact your local representative or sales office.



MELFA-3D Vision



Picking of discretely placed parts



Model-less recognition

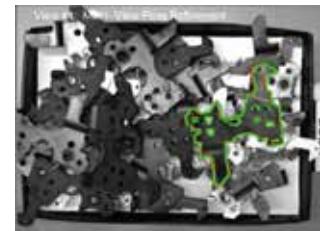

Model matching recognition

Collision Avoidance

iQ Platform [Q type controllers only]

For automatic prevention of collisions between robots

The software constantly monitors robots motion, predicts collisions before they occur, and immediately stops the robots. This avoids damage to the robot during both the JOG operations and automatic mode operations.

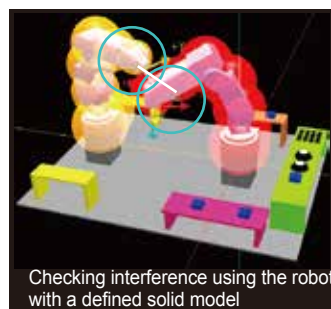
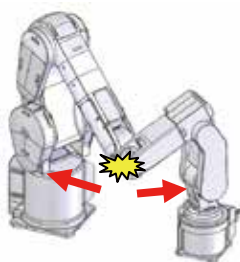

Checking interference using the robot with a defined solid model

Decreases downtime during startup operation

Reduces the number of recovery man-hours required after collisions due to teaching operation errors or failure to set interlocks

Coordinated control

iQ Platform [Q type controllers only]

Coordinated control between multiple robots

Enables coordinated control between multiple robots through CPU connection between the robots. Easy to operate and use under normal operation through individual robot operation.



Enables installation work to be completed while gripper positions between robots are maintained.

Coordinated transport

Enables transport of lengthy or heavy objects using multiple small-sized robots instead of larger ones.

Force control function

Highly-accurate mating operation, quality assurance, reliability improvement

Flexible control + Error detection

The robot can be flexibly controlled and operated profiling the target workpiece.

When a workpiece is inserted with an excessive force, an error is generated to stop the operation.

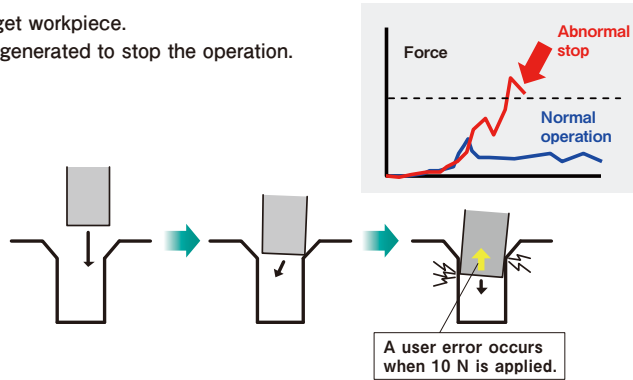
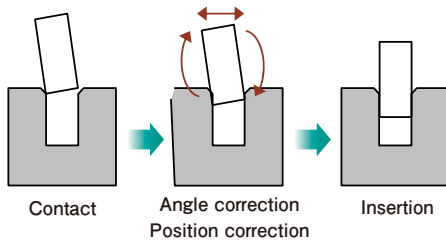

Performs complex assembly works such as phase focusing.

Operation change with force detection

Contact detection switches operation directions or force controls.

This function realizes highly-flexible assembly works by changing the force control characteristics during interpolation operation.

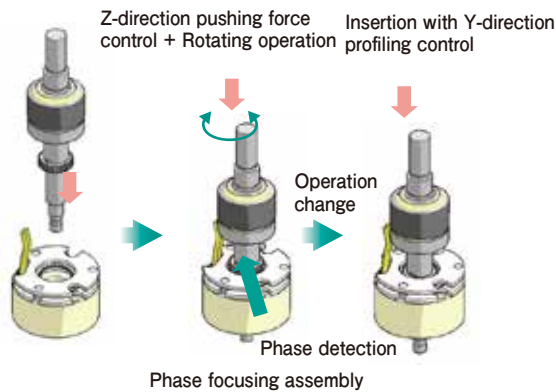

Performs operations with a constant force.

Pushing force control

A robot performs pushing operations in a specified direction with a constant force. This control can also be used for deburring works and tension applying works.

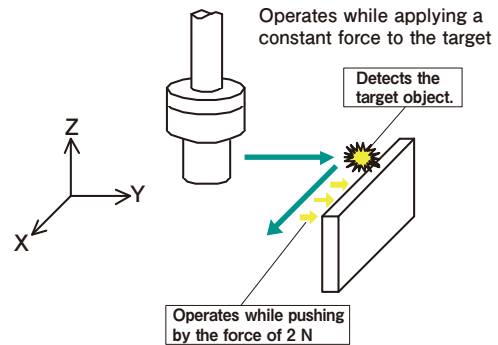

Teaching support

Force GUI has been installed.

- Because force GUI screens are utilized for the personal computer support software (RT ToolBox2) and teaching boxes (R56TB/R57TB, R32TB/R33TB) as standard, users can easily operate force sensors.
- The force data synchronized with position data can be saved as log data.
- RT ToolBox2 displays log data in a graph.
- Log data files can be transferred to a personal computer via FTP.

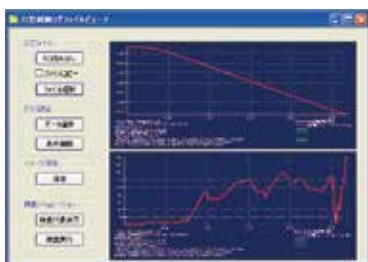

■ Force log (RT ToolBox2 log viewer)



R32TB/R33TB



R56TB/R57TB



Users can perform teaching while checking the force status on the force control-dedicated screen of the teaching boxes, realizing the optimal position teaching.

Multifunctional electric hand

The highly-functional operation control that cannot be performed with air cylinders

Users can set the grip force and gripping speed depending on a target workpiece, such as a soft one and heavy one. When users need to handle workpieces with different sizes, they can set the optimal stroke in the operating position setting. Position feedback of hands can be utilized for the judgments of success/failure in gripping and OK/NG products with the measurement of workpiece dimensions and product inspections.

Prevents interference using the opening/closing stroke control

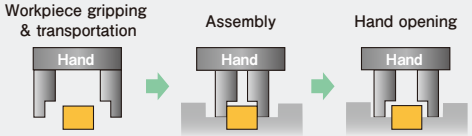

<Benefits of electric hands>

- ◎ Multipoint position control (applicable to a wide variety of products, opening/closing stroke adjustment)

Prevents deformation of resin moldings

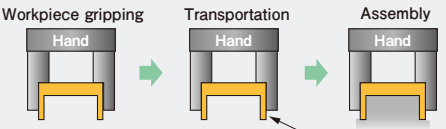

<Benefits of electric hands>

- ◎ Speed control (workpiece shape retention, impact cushioning)
- ◎ Grip force control (prevention of workpiece deformation)

Please contact your local representative or sales office.



● Multifunctional electric hand (manufactured by TAIYO)

Easy control

With a robot program, users can easily set the operation stroke and grip force according to the dimensions of workpieces.



Easy operation

Users can flexibly operate electric hands on the hand-dedicated screen of the teaching box.

Robot Lineup

Series configuration of vertical, multiple-joint type robots

Model													
	RV-2F	RV-2FL	RV-4F	RV-4FL	RV-7F	RV-7FL	RV-7FLL	RV-13F	RV-13FL	RV-20F	RV-35F	RV-50F	RV-70F
Maximum load capacity	3kg		4kg		7kg			13kg		20kg	35kg	50kg	70kg
Reach	504mm	649mm	515mm	649mm	713mm	908mm	1503mm	1094mm	1388mm	1094mm	2050mm		

Series configuration of horizontal, multiple-joint type robots

Model															
	RH-3FH			RH-6FH			RH-12FH			RH-20FH			RH-3FHR		
Maximum load capacity	3kg			6kg			12kg			20kg			3kg		
Reach	350mm	450mm	550mm										350mm		
				350mm	450mm	550mm	700mm	850mm	1000mm						
Z stroke	150mm*1												150mm*2		
				200mm											
				340mm			350mm			450mm					

*1: Clean room specification machine: 120mm *2: Clean room specification machine, waterproof specification machine: 120mm

Controller type

Q-TYPE controller

This type of controller is compatible with "iQ Platform" that seamlessly integrates controllers, HMIs, engineering environment, and networks in a manufacturing site. A multiple-CPU configuration dramatically improves the compatibility with FA devices, and allows users to perform elaborate controls and information management fast and easily.

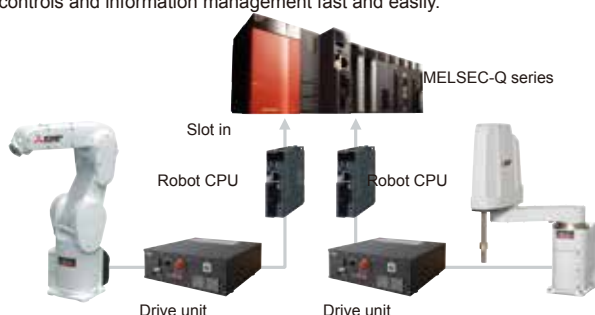

D-TYPE controller

This type of controller is a stand-alone type, just like conventional controllers. Cells can be built by using a robot controller as the core of a control. Because various interfaces have been mounted into a robot controller as standard, the most suitable system can be configured in accordance with your application.

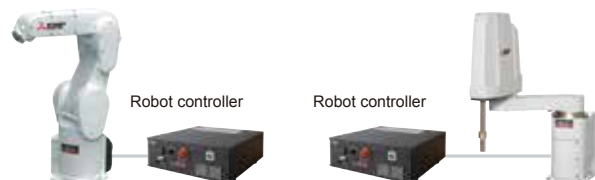

Global FA centers



China

Shanghai FA Center MITSUBISHI ELECTRIC AUTOMATION (CHINA) LTD.

No.1386 Hongqiao Road, Mitsubishi Electric Automation Center, Shanghai, China
Tel : 86-21-2322-3030
Fax: 86-21-2322-3000(9611#)

Beijing FA Center MITSUBISHI ELECTRIC AUTOMATION (CHINA) LTD. Beijing Branch

Unit 901, 9F, Office Tower 1, Henderson Centre, 18 Jianguomennei Avenue, Dongcheng District, Beijing, China
Tel : 86-10-6518-8830
Fax: 86-10-6518-2938

Tianjin FA Center MITSUBISHI ELECTRIC AUTOMATION (CHINA) LTD. Tianjin Branch

Room 2003 City Tower, No.35, Youyi Road, Hexi District, Tianjin, China
Tel : 86-22-2813-1015
Fax: 86-22-2813-1017

Guangzhou FA Center MITSUBISHI ELECTRIC AUTOMATION (CHINA) LTD. Guangzhou Branch

Room 1609, North Tower, The Hub Center, No.1068, Xingang East Road, Haizhu District, Guangzhou, China
Tel : 86-20-8923-6730
Fax: 86-20-8923-6715

Korea

Korea FA Center MITSUBISHI ELECTRIC AUTOMATION KOREA CO., LTD.

7F~9F, Gangseo Hangang Xi-tower A, 401, Yangcheon-ro, Gangseo-Gu, Seoul 157-801, Korea
Tel : 82-2-3660-9605/9606/9607
82-2-3660-9632(PLC/HMI)
82-2-3660-9630(SV/INV/Robot)
82-2-3660-9631(NC)
Fax: 82-2-3663-0475

Taiwan

Taichung FA Center MITSUBISHI ELECTRIC TAIWAN CO.,LTD.

No.8-1, Industrial 16th Road, Taichung Industrial Park, Taichung City 40768, Taiwan, R.O.C.
Tel : 886-4-2359-0688
Fax: 886-4-2359-0689

Asean

ASEAN FA Center MITSUBISHI ELECTRIC ASIA PTE. LTD.

307, Alexandra Road, Mitsubishi Electric Building, Singapore 159943
Tel : 65-6470-2480(FA)
65-6470-2413(NC)
Fax: 65-6476-7439

Indonesia

Indonesia FA Center PT. MITSUBISHI ELECTRIC INDONESIA Cikarang Office

Jl. Kenari Raya Blok G2-07A Delta Silicon 5, Lippo Cikarang - Bekasi 17550, Indonesia
Tel : 62-21-2961-7797
Fax: 62-21-2961-7794

Vietnam

Hanoi FA Center MITSUBISHI ELECTRIC VIETNAM COMPANY LIMITED Hanoi Branch

6 - Floor, Detech Tower, 8 Ton That Thuyet Street, My Dinh 2 Ward, Nam Tu Liem District, Hanoi, Vietnam
Tel : 84-4-3937-8075
Fax: 84-4-3937-8076

Ho Chi Minh FA Center MITSUBISHI ELECTRIC VIETNAM COMPANY LIMITED

Unit 01-04, 10th Floor, Vincom Center, 72 Le Thanh Ton Street, District 1, Ho Chi Minh City, Vietnam
Tel : 84-4-3937-8075
Fax: 84-4-3937-8076

Thailand

Thailand FA Center MITSUBISHI ELECTRIC FACTORY AUTOMATION (THAILAND) CO., LTD.

12th Floor, SV.City Building, Office Tower 1, No. 896/19 and 20 Rama 3 Road, Kwaeng Bangpongpan, Khet Yannawa, Bangkok 10120, Thailand
Tel : 66-2682-6522~31
Fax: 66-2682-6020

India

India Pune FA Center MITSUBISHI ELECTRIC INDIA PVT. LTD. Pune Branch

Emerald House, EL -3, J Block, M.I.D.C Bhosari, Pune - 411026, Maharashtra, India
Tel : 91-20-2710-2000
Fax: 91-20-2710-2100

America

North America FA Center MITSUBISHI ELECTRIC AUTOMATION, INC.

500 Corporate Woods Parkway, Vernon Hills, IL 60061, U.S.A.
Tel : 1-847-478-2100
1-847-478-2500(NC)
Support in Japanese
1-847-478-2469 PLC/HMI
1-847-478-2334 INV/SV
Tel
1-800-950-7781
Fax: 1-847-478-2253
1-847-478-2650(NC)
1-847-478-2396(LVS,MC)

Brazil

Brazil FA Center MITSUBISHI ELECTRIC DO BRASIL COMÉRCIO E SERVIÇOS LTDA.

Rua Jussara, 1750- Bloco B Anexo, Jardim Santa Cecilia, CEP 06465-070, Barueri - SP, Brasil
Tel : 55-11-4689-3000
Fax: 55-11-4689-3016

Europe

Europe FA Center MITSUBISHI ELECTRIC EUROPE B.V. Polish Branch

ul. Krakowska 50, 32-083 Balice, Poland
Tel : 48-12-630-47-00 48-12-630-47-81 (Japanese)
Fax: 48-12-630-47-01

Germany FA Center MITSUBISHI ELECTRIC EUROPE B.V. German Branch

Gothaer Strasse 8, D-40880 Ratingen, Germany
Tel : 49-2102-486-0
Fax: 49-2102-486-1120

UK FA Center MITSUBISHI ELECTRIC EUROPE B.V. UK Branch

Travellers Lane, Hatfield, Hertfordshire, AL10 8XB, U.K.
Tel : 44-1707-28-8780
Fax: 44-1707-27-8695

Czech Republic FA Center MITSUBISHI ELECTRIC EUROPE B.V. Czech Branch

Avenir Business Park, Radlicka 751/113e, 158 00 Praha5, Czech Republic
Tel : 420-251-551-470
Fax: 420-251-551-471

Russia FA Center MITSUBISHI ELECTRIC EUROPE B.V. Russian Branch St. Petersburg office

Piskarevsky pr. 2, bld 2, lit "Sch", BC "Benua", office 720; 195027, St. Petersburg, Russia
Tel : 7-812-633-3497
Fax: 7-812-633-3499

Turkey FA Center MITSUBISHI ELECTRIC TURKEY A.Ümraniye Branch

Serifali Mahallesi Nutuk Sokak No:5, TR-34775 Ümraniye, Istanbul, Turkey
Tel : 90-216-526-3990
Fax: 90-216-526-3995

MEMO

A series of horizontal dotted lines for writing, spanning the width of the page.

YOUR SOLUTION PARTNER

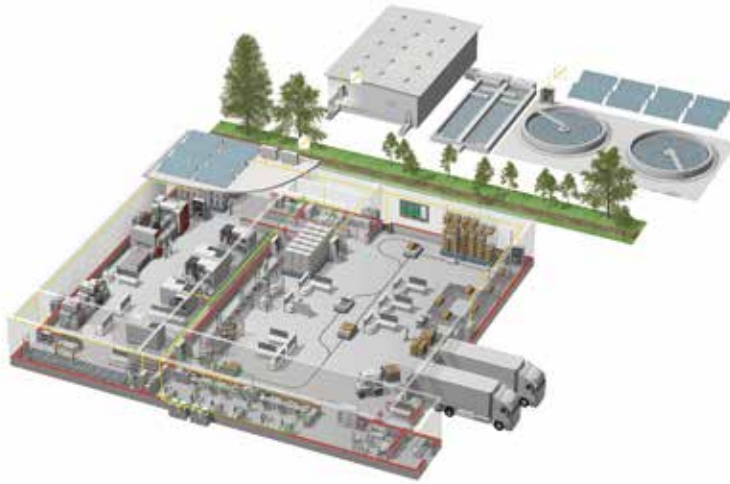

Mitsubishi Electric delivers a wide variety of FA products including FA devices, such as programmable controllers and AC servos, and industrial mechatronics products, such as CNC and industrial robots.

TO A MOST RELIABLE BRAND IN MANUFACTURING SITES

Mitsubishi Electric deploys various FA (factory automation) businesses covering from components to processing machines, and assists production systems in various fields for a goal of productivity improvement and quality improvement. With a system fully covering from development and manufacturing to quality assurance, Mitsubishi Electric is studying customer needs to produce products satisfying them.

Further, Mitsubishi Electric offers reliable and safe technical supports through its unique global network all over the world. The FA business of Mitsubishi Electric always offers the front-line solutions and contributes to the global manufacturing through close communication with customers.



Low-voltage Circuit Breakers, Motor Starters



High-voltage Circuit Breakers, High-voltage Contactors



Energy Saving Supporting Devices, Power Monitoring Products



Programmable Controllers, HMIs (Human-Machine Interfaces)



AC Servos, Three-phase Motors, IPM Motors
Inverters, Geared Motors



Computerized Numerical Controllers (CNCs)



Industrial Robots



Electrical Discharge Machines, Laser Processing Machines,
Electron Beam Machines



Distribution Transformers



Pressurized Ventilation Fans, Uninterruptible Power Supplies

GLOBAL PARTNER. LOCAL FRIEND

American Offices

USA Mitsubishi Electric Automation, Inc. 500 Corporate Woods Parkway, Vernon Hills, IL 60061, USA. Tel: +1-847-478-2100	Brazil Mitsubishi Electric do Brasil Comercio e Servicos Ltda. Rua Jussara, 1750- Bloco B- Sala 01, Jardim Santa Cecilia, CEP 06465-070, Barueri - SP, Brasil Tel: +55-11-4689-3000
--	---

Asia-Pacific Offices

China Mitsubishi Electric Automation (China) Ltd. No.1386 Hongqiao Road, Mitsubishi Electric Automation Center 3F Shanghai, China Tel: +86-21-2322-3030	Taiwan Mitsubishi Electric Taiwan Co., Ltd. 10F.No.88,Sec.6,Chung-Shan N.Rd.,Taipei,Taiwan Tel: +886-02-2833-5430	Korea Mitsubishi Electric Automation Korea Co., Ltd. 7F-9F, Gangseo Hangang Xi-tower A, 401, Yangcheon-ro, Gangseo-Gu,Seoul 157-801, Korea Tel: +82-2-3660-9550
Singapore Mitsubishi Electric Asia Pte. Ltd. 307 Alexandra Road #05-01/02, Mitsubishi Electric Building, Singapore Tel: +65-6470-2480	Thailand Mitsubishi Electric Automation (Thailand) Co., Ltd. Bang-Chan Industrial Estate No.111 Soi Serithai 54, T.Kannayao, Bangkok 10230 Thailand Tel: +66-2517-1326	India Mitsubishi Electric India Pvt. Ltd. Emerald House, EL -3, J Block, M.I.D.C., Bhosari, Pune - 411026, Maharashtra State, India Tel: +91-2710-2000

European Offices

Germany Mitsubishi Electric Europe B.V. German Branch Gothaer Strasse 8, D-40880 Ratingen, Germany Tel: +49-2102-486-0	UK Mitsubishi Electric Europe B.V. UK Branch Travellers Lane, Hatfield, Hertfordshire, AL10 8XB, U.K. Tel: +44-1707-27-6100	Italy Mitsubishi Electric Europe B.V. Italian Branch VIALE COLLEONI 7-20041 Agrate Brianza(Milano),Italy Tel: +39-039-60531
Spain Mitsubishi Electric Europe B.V. Spanish Branch Carretera de Rubi 76-80-AC.4720, E-08190 Sant Cugat del Valles (Barcelona), Spain Tel: +34-935-65-3131	France Mitsubishi Electric Europe B.V. French Branch 25, Boulevard des Bouvets, F-92741 Nanterre Cedex, France Tel: +33-1-5568-5568	Czech Republic Mitsubishi Electric Europe B.V. Czech Branch Avenir Business Park, Radicka 714/113a,158 00 praha5, Czech Republic Tel: +420-251-551-470
Poland Mitsubishi Electric Europe B.V. Polish Branch ul. Krakowska 50 32-083 Balice, Poland Tel: +48-12-630-47-00	Ireland Mitsubishi Electric Europe B.V. Irish Branch Westgate Business Park, Ballymount. IRL-Dublin 24 Tel: +353-14198800	Russia Mitsubishi Electric Europe B.V. Russian Branch Moscow Office 52. bld. 3, Kosmodamianskaya nab., RU-115054, Moscow, Russia Tel: +7-495-721-2070



MITSUBISHI ELECTRIC CORPORATION

HEAD OFFICE: TOKYO BLDG., 2-7-3 MARUNOUCHI,
 CHIYODA-KU, TOKYO 100-8310, JA PAN